

Plumbing & Heating Systems

International Product Guide



POLYPIPE OVERVIEW

Agritwin

DOMUS

Effast

Hydro8

Overlay

Flexicon

Janoplast

Oracstar

Polysoak

Polyguard

Polyduct

 Polypipe

POLYPLUMB

POLYFIT

Polypress

Polysewer

Ridgicoil

Polystorm

Ridgidrain

Ridgiduct

TERRAIN

Ridgistorm

Ridgisewer

Ridgistorm

Stormcheck

TDI

Made up of 28 principal brands across 10 companies, with over 1,900 employees across Europe and the Middle East, Polypipe manufactures a comprehensive range of plastic piping systems for the residential, commercial and infrastructure markets. From its foundation in 1980, Polypipe has grown into a global organisation, producing some 15,000 products for water, air, energy and telecoms applications.

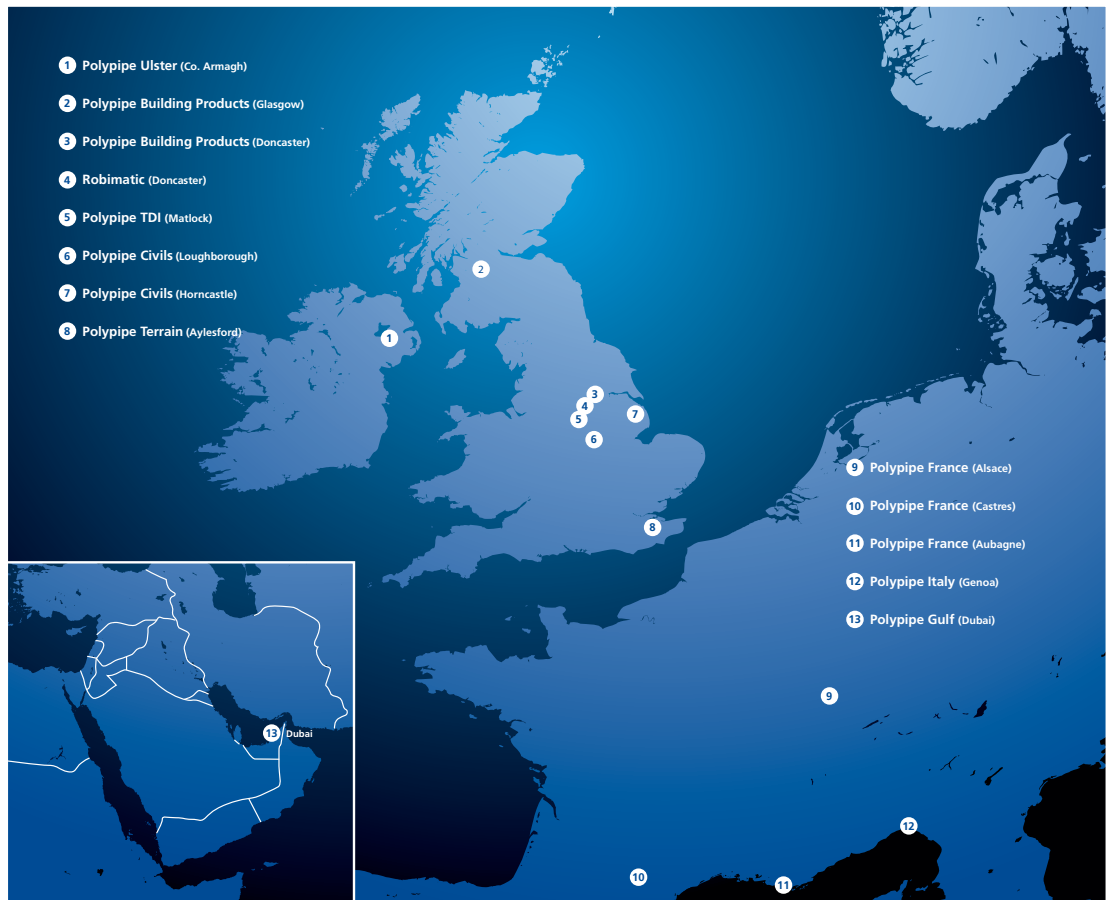

Polypipe brands

Synonymous with quality and durability, we recognise that end-users place a great deal of reliance on the integrity of our piping system brands. They need to have confidence that today's installed product meets both their own design criteria, as well as growing and

increasingly stringent levels of performance characteristics to meet both national and European-wide approvals and standards. Our brands are the symbol of our continued commitments to meet and exceed these standards.

POLYPIPE PLUMBING & HEATING SYSTEMS

Polypipe is the UK's leading and fastest growing manufacturer of plastic plumbing products for hot and cold plumbing and heating systems. Our products serve the domestic and commercial market, providing installers and end users with easy to install, reliable products.

At Polypipe we have a commitment to delivering products that meet every conceivable need within our chosen market sectors, with each range designed to provide outstanding innovation, performance and value.

The manufacturer of choice

Polypipe as a UK manufacturer is a key player in the worldwide plumbing market with an unrivalled reputation for innovation, service and value.

In recent years, Polypipe has consistently outstripped the overall market growth of plastic plumbing & heating systems as a growing number of distributors, developers, MEP engineers and clients recognise the benefits of the company's product offering.

At the heart of the Polypipe range is a firm belief in creating products suited to specific applications. Long since recognised for our Polyplumb and Polyfit ranges, we have now added Polysure to the range complimenting our existing ranges, offering a solution for all applications. All three ranges are fully described in this product guide.

Backing up our versatile collection of fitting types is our commitment to piping systems. We again have options in the range of pipe, polybutylene – well known for flexibility to create the most efficient plumbing and heating solutions available, Polypipe is also recognised for its innovative channel support initiatives, which provide distributors, developers and installers with access to a wide range of market support, including literature, point of sale materials and technical information.

With great products, great service and great value, backed by outstanding channel support and a track record for product and market innovation, Polypipe is increasingly becoming the plumbing sector's manufacturer of choice.

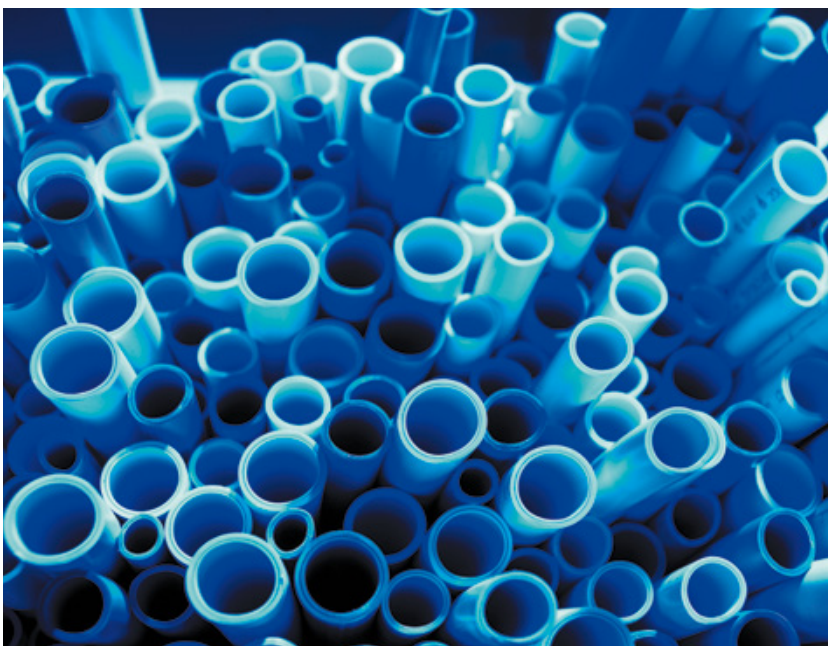

Plumbing & Heating Systems

Outstanding performance & value	5
Polybutylene Pipe	6
Polyplumb system	8
Installing Polyplumb system	9
Polyplumb product range	11
Polyfit system	19
Installing Polyfit system	20
Polyfit product range	21
Polysure system	29
Installing Polysure system	30
Polysure product range	33
Design, Application and Installation Information	37
System testing	46
Extensive support services	46
Centre of Excellence	47

In this Product Guide any references to generic terms such as “the products”, “our plumbing systems”, or similar terms, are intended to refer to Polyplumb, Polyfit and Polysure systems.

OUTSTANDING PERFORMANCE & VALUE

Application driven product options

Polypipe has developed three distinct plumbing systems, each designed to meet its own set of application criteria. Polypipe enables you to choose the system most appropriate for your project, match it with the correct Polypipe pipe, and install the system with confidence.

Use the overview below as a quick guide to our products and consult the individual product sections within this product guide for more detailed information.



FM00318

POLYPLUMB



The **FAST** and **PERMANENT** one

Choose Polyplumb for a fast, reliable and permanent fitting

Our original plumbing system, using technology tried and tested for over 30 years, Polyplumb provides a superb combination of fast fitting with a permanent, reliable fix. Polyplumb offers a one-step joint process, with joint integrity assured by a high performance, stainless steel grab ring within the fitting.

Polyplumb can only be demounted by dis-assembly, reducing the risk of tampering.

POLYFIT



The **FAST** and **DEMOUNTABLE** one

Choose Polyfit when you need speed and demountability

The “push-click, that’s it” feature of our Polyfit system makes it the market leader in speed to fit. With its unique one-step operation, with no need for a quarter locking turn, Polyfit will lock tight for a secure fit and to prevent accidental release.

Polyfit systems can be easily demounted and re-used if required.

POLYSURE



The **SLIM** and **PERMANENT** one

Choose Polysure when you want a slim and secure fitting

Polysure is the latest introduction to the Polypipe range and is the first plumbing fitting to bring you the best in emerging radial press fit technology in UK sizes.

Polysure fittings are slim profile and are applied using a specialist pressing tool to ensure the most secure and permanent fix, making it ideal for applications where a tamper proof solution is important.

The nature of Polysure fittings means that they cannot be demounted.

POLYBUTYLENE PIPE: FLEXIBLE & SUSTAINABLE



At the heart of our systems is our commitment to polybutylene pipe. Unlike a number of other plumbing manufacturers, we choose polybutylene to create the most flexible and efficient pipes and plumbing systems available. Polybutylene pipe is ideal for both domestic hot and cold water plumbing and heating systems, offering exceptional durability and long-term performance, which has seen it become the preferred material choice for today's building projects.

The most important characteristic of polybutylene is its natural flexibility, allowing you to bend, curve and manipulate the pipe into even the tightest of spaces. Polybutylene is the most malleable plastic used in the manufacture of piping systems.

The table below shows the modulus of elasticity or rigidity of polybutylene compared with a range of piping systems:

Flexural Elasticity Modulus (MPa) Method ISO 178

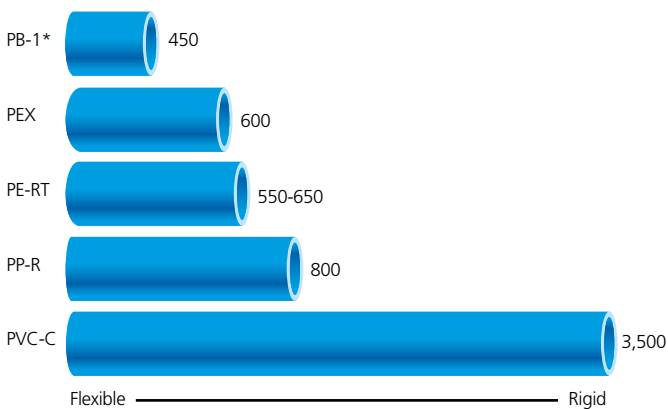

*PB-1 is the chemical name for Polybutylene

Within the manufacturing cycle polybutylene doesn't require chemical or radiation cross linking, which reduces the number of production processes, leading to faster and more efficient manufacturing.

Polybutylene pipe has good resistance to freezing temperatures, maintaining long-term durability in heating and water applications. This, combined with the pipe's elasticity, means that if water is subjected to freezing temperatures, the result will be a reduced possibility of burst pipes.

Polybutylene pipe has low thermal conductivity. Its co-efficient of thermal expansion is $1.3 \times 10^{-4} \text{m/m}^\circ\text{C}$. It accommodates expansion by its natural flexibility.

Our plumbing systems give better performance than rigid pipe systems in terms of low noise transmission and low water hammer effect.

The table below highlights the sound velocity of polybutylene pipe compared with other materials:

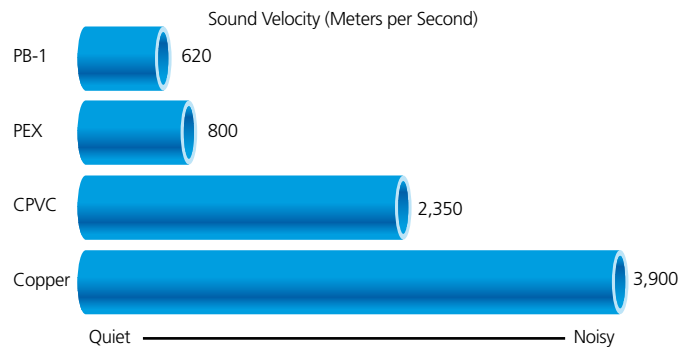

 Polypipe Building Products is a member of the Polybutylene Piping Systems Association (PB.P.S.A), which is a recognised association of companies whose aim is to promote the features, benefits and best practice installation techniques of polybutylene pipe systems, as well as providing a wide range of technical information and support

Pipe options

Polypipe offers a range of pipe options and sizes to complement each of our fitting systems and to suit every project.



Grey Polyplumb polybutylene pipe, available in standard 'monolayer' and barrier versions.



White Polyfit polybutylene pipe, available in barrier versions only.

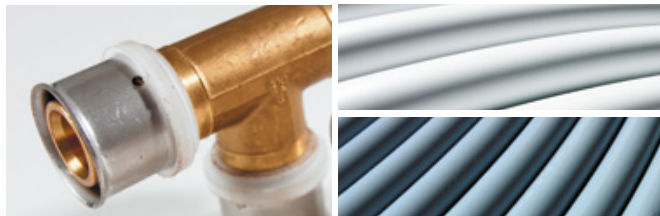

Polysure can be used with either white or grey polybutylene pipe.



Polyplumb pipe in pipe systems consist of a polybutylene barrier pipe encased within a black conduit pipe. The conduit provides protection for the polybutylene pipe during the installation process, as well as allowing easy withdrawal for future alteration or maintenance.

The conduit pipe coils allow 15mm and 22mm Polyplumb pipe to be laid in a concrete floor with concrete walls. When conduit pipe is used in conjunction with conduit boxes, it provides a cost effective and practical solution, as an alternative to other ducting systems.

Pipe selection

Cut length or "Plumb straight"

Although "Plumb Straight" coiled pipe is designed to effectively straighten when un-coiled, where the visual appearance of pipe is important, i.e. short visible sections of 22mm pipe in cylinder cupboards, pipe cut from straight lengths may be preferred.

NOTE: Polybutylene pipe must not be used for long permanently exposed runs of pipe where appearance is important. Both straight and coiled pipes are flexible.

Standard or Barrier

As barrier pipes contain an EVOH barrier layer to reduce oxygen ingress into the system through the pipe wall it is our opinion that these pipes must be used on central heating systems. When tested to DIN 4726 and DIN 4727 barrier pipes give an oxygen permeability less than the value of 0.1g (m3d) specified in DIN 4726. The use of corrosion inhibitor in central heating systems is acceptable provided that the inhibitor is specifically designed for plastic piping systems and guidance on their suitability should be sought from the inhibitor manufacturer prior to adding to the system.

Both barrier and standard pipes can be used in hot and cold water supplies.

PIPE LENGTH	PIPE SIZE							
	10mm		15mm		22mm		28mm	
	white	grey	white	grey	white	grey	white	grey
2m			●		●			
3m			●	●	●	●	●	●
6m			●	●	●	●	●	●
25m	●		●	●	●	●	●	●
50m	●	●	●	●	●	●	●	●
100m	●	●	●	●				
120m			●					
150m			●	●				

Pipe in pipe is available in grey only in the following variants:

- 10mm x 50m • 15mm x 25 and 50m • 22mm x 25m

Plain conduit pipe is available for 15mm and 22mm pipes in 25m and 50m lengths in black, red and blue.

POLYPLUMB SYSTEM

POLYPLUMB



Polyplumb is an integrated flexible plumbing system, incorporating polybutylene pipes and a complimentary range of push-fit fittings. It can be used in hot and cold water supply, and radiator and floor heating installations. The system offers a high degree of reliability, achieved through a product design that has been tried and tested over the past 30 years.

The system offers a number of benefits, including:

- Time efficient, no nonsense one step joint process
- High performance stainless steel grab ring ensures superb joint integrity
- Demountable only by dis-assembling, reducing potential for tampering
- The original Polypipe pushfit plumbing system used and relied on by customers throughout the world

Joining

There are five vital stages to successfully joining the Polyplumb system.

Cutting Polyplumb pipes

Step 1a:

Firstly check that the pipe is not scored or scratched in any way and if it is so cut back to a point where there is no damage present. Always use one of the approved pipe cutters (code PB781 or PB778). A slight rotation of the pipe when cutting will help make cutting easier. Never use a hacksaw and always cut on a depth insertion mark. These "K" shaped marks are equally spaced along the pipe and indicate the depth required for full insertion in to a Polyplumb socket fitting.



Insertion depth markers on fittings

Each fitting now has an insertion depth marker on the fitting body to aid with installation. The only way of being certain that a joint has been completed successfully is by using the insertion depth marks on the pipe for cutting and insertion purposes.

Use of pipe stiffener

Step 2:

Pipe stiffeners are an integral part of the joint when using Polyplumb pipe with either Polyplumb fittings or compression fittings and need to be fully inserted in to the pipe end.



Visual check of fitting and fitting components

Step 3:

Although every single socket is visually checked during the manufacturing process to ensure that all components are present and in the correct order, a further visual check must be carried out as tampering by others can take place on site or during distribution.

CAUTION - Do not insert fingers into the Polyplumb fittings, as the grab ring is sharp and designed to grip.

Insert pipe fully into fitting

Step 4:

The pipe should be inserted into the fitting to full socket depth such that the insertion depth mark aligns with the outer end of the cap nut on the fitting.



Grab ring check

Step 5:

A quick tug on the pipe will confirm that the pipe is inserted past the grab ring and that a grab ring was present in the fitting. It does not however ensure that the pipe is fully inserted as this can only be confirmed by using the depth insertion mark.

IMPORTANT NOTE: Avoidance of re-joining

On no account should a pipe be removed from a jointed Polyplumb fitting by removing the cap-nut and withdrawing the pipe end complete with all the socket components from the fitting to be re-joined without removing and replacing the grab-ring into the fitting and re-making the joint in accordance with the normal Polyplumb joining procedure.

If the pipe end complete with all the socket components is subsequently re-joined into the body of a fitting, there is a risk that the outer edge of the grab-ring could catch on the outer end or the inside surface of the socket of the fitting which forces the grab-ring into an angled position on the pipe. Forcing the grab-ring into an angled position on the pipe in this way, seriously damages the grab-ring teeth and will reduce the pull-out performance of the joint when subjected to pressure, such that premature failure will almost certainly occur with the potential for serious injury.

WARNING

All joining instructions must be followed at all times with particular attention being paid to correct insertion depths. If a pipe is not inserted fully into a fitting through both the O ring seal and the grab ring then the incorrect assembly will come apart. The pipe will then have an open end which will result in water discharging unintentionally. As our products can be used on hot water and heating systems there is the potential for serious injury should this situation occur with hot water.

Cutting copper pipe for insertion in a Polyplumb fitting

Wherever possible, use a rotational pipe cutter when cutting copper pipe. Ensure that all cut ends have a rounded lead in, with burrs removed. **Never use a hacksaw.** You will need to mark the insertion depth on the pipe as below.

Insertion Depth				
Pipe diameter (mm)	10	15	22	28
Insertion depth (mm)	22	27	30	35

Dismantling a Polyplumb joint

Polyplumb fittings must not be dismantled for any reason prior to jointing.

Procedure for using the component pack of spares Dismantling the joint

Step 1:

If it is necessary to remove a jointed pipe from a fitting, the cap-nut should be unscrewed and the pipe with all the socket components present on the pipe end should be pulled out of the socket of the fitting. The pipe end complete with all the socket components should be cut off and discarded. A complete component pack of socket spares should be fitted to the socket as described below and pipe jointing should be carried out as described left.

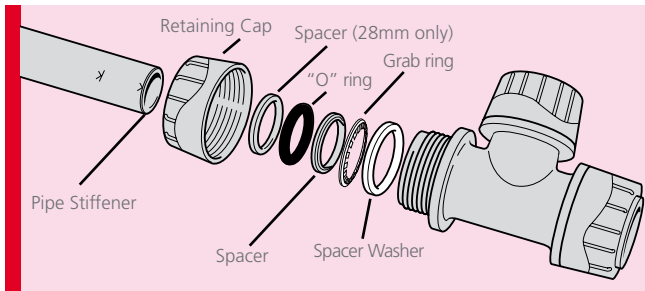

Polyplumb fittings general arrangement

Replacement components

Step 2:

The component pack (Code: PB95XX) is supplied as a cap-nut with all the socket components present in the correct order and retained by a retaining cap.

Preparing components

Step 3:

Completely remove the retaining cap, ensuring that the socket components remain within the cap-nut.

Replacing the components

Step 4:

Without removing any of the socket components from the cap-nut, introduce the cap-nut and socket components to the socket of the fitting and tighten up the cap-nut by hand ensuring that the components enter the socket without snagging.

Checking the fitting

Step 5:

Carry out a visual check to ensure that all socket components are present in the correct order as shown in the diagram and that the rubber 'O'ring is lubricated. If in doubt, the 'O'ring should be re-lubricated using Polyplumb silicone lubricant.

Reduced component fittings

Changes have been made to 15mm Polyplumb couplers, elbows and tees and 22mm Polyplumb elbows and tees, which need to be considered when using Polyplumb spares kits with these fittings, as follows:

Original Polyplumb fittings

Step 1:

If the bottom white washer is present in the fitting below the grab-ring, then the spares kit can be used as supplied without making any changes.

New Polyplumb fittings

Step 2:

If there is no bottom white washer present below the grab-ring with one of the five listed fittings then this is one of the fittings which has been modified.



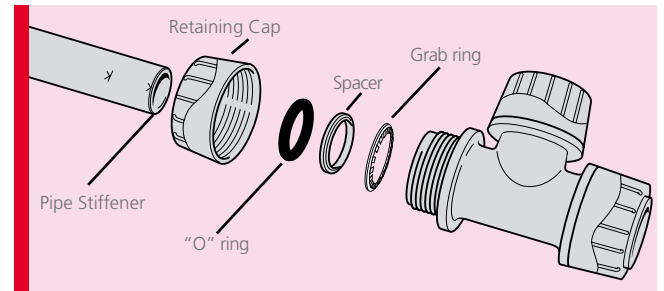





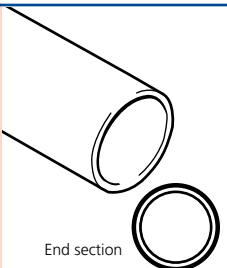

Before the spares kit is used, the carrier moulding should be carefully removed from the cap-nut and the bottom white washer should be removed and discarded without changing the order of any of the other components. After this has been done, the spares kit should be offered up to the socket of the fitting, inserting the components into the socket in the order they are within the kit and then screwing down the cap-nut onto the outside of the socket.

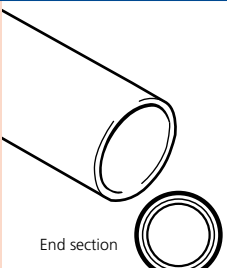

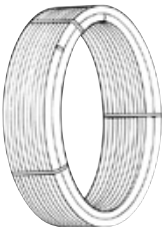

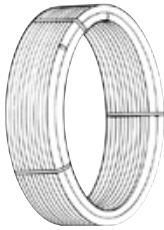

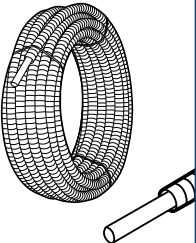

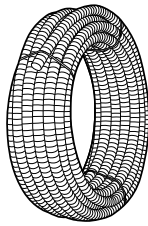



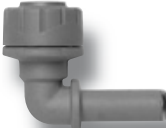



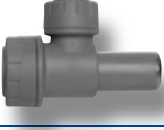





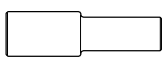

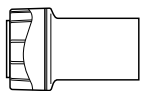

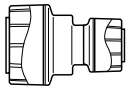

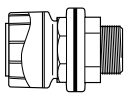

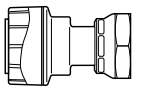
15mm couplers, elbows and tees and 22mm elbows and tees

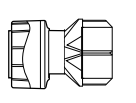

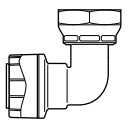



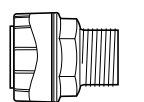

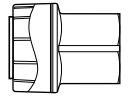

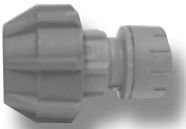
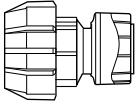

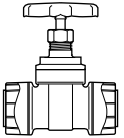

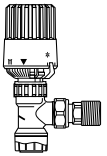
System testing

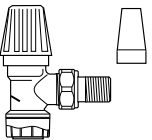

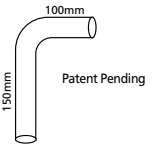

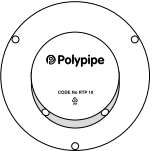





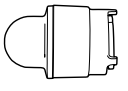
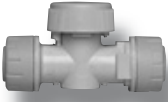
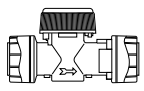
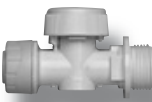
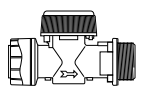

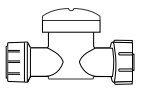

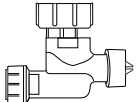

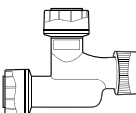
Prior to completing installation it is necessary to fully test the installed system. Please refer to the section on page 46 of this Product Guide for system testing guidance.

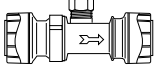
COMPONENT	PRODUCT DESCRIPTION	PACK QUANTITY	CODE NUMBER	
	<p>Standard Polybutylene Pipe Cut Length</p> <p>15mm x 3 metre Cut Length 15mm x 6 metre Cut Length 22mm x 3 metre Cut Length 22mm x 6 metre Cut Length 28mm x 3 metre Cut Length 28mm x 6 metre Cut Length</p>	<p>10 10 10 10 10 10</p>	<p>PB315 PB615 PB322 PB622 PB328 PB628</p>	 <p>End section</p>
	<p>Barrier Polybutylene Pipe Cut Length</p> <p>15mm x 3 metre Cut Length 15mm x 6 metre Cut Length 22mm x 3 metre Cut Length 22mm x 6 metre Cut Length 28mm x 3 metre Cut Length 28mm x 6 metre Cut Length</p>	<p>10 10 10 10 10 10</p>	<p>PB315B PB615B PB322B PB622B PB328B PB628B</p>	 <p>End section</p>
	<p>Standard Polybutylene Pipe Coils Featuring "Plumb Straight" coiling technology</p> <p>10mm x 50 metre Coil 10mm x 100 metre Coil 15mm x 25 metre Coil 15mm x 50 metre Coil 15mm x 100 metre Coil 22mm x 25 metre Coil 22mm x 50 metre Coil</p>	<p>1 1 1 1 1 1 1</p>	<p>PB5010 PB10010 PB2515 PB5015 PB10015 PB2522 PB5022</p>	
	<p>Barrier Polybutylene Pipe Coils Featuring "Plumb Straight" coiling technology</p> <p>10mm x 50 metre Coil 10mm x 100 metre Coil 15mm x 25 metre Coil 15mm x 50 metre Coil 15mm x 100 metre Coil 15mm x 150 metre Coil 22mm x 25 metre Coil 22mm x 50 metre Coil 28mm x 25 metre Coil 28mm x 50 metre Coil</p>	<p>1 1 1 1 1 1 1 1 1 1</p>	<p>PB5010B PB10010B PB2515B PB5015B PB10015B PB15015B PB2522B PB5022B PB2528B PB5028B</p>	
	<p>Barrier Pipe-in-Pipe</p> <p>10mm x 50 metre Coil 15mm x 25 metre Coil 15mm x 50 metre Coil 22mm x 25 metre Coil</p>	<p>1 1 1 1</p>	<p>PIP5010B PIP2515B PIP5015B PIP2522B</p>	
	<p>Conduit Pipe Coils (Polypropylene)</p> <p>15mm x 25 metre Conduit Pipe Coil (Black) 15mm x 50 metre Conduit Pipe Coil (Black) 22mm x 25 metre Conduit Pipe Coil (Black) 22mm x 50 metre Conduit Pipe Coil (Black) 15mm x 25 metre Conduit Pipe Coil (Red) 15mm x 50 metre Conduit Pipe Coil (Red) 22mm x 25 metre Conduit Pipe Coil (Red) 22mm x 50 metre Conduit Pipe Coil (Red) 15mm x 25 metre Conduit Pipe Coil (Blue) 15mm x 50 metre Conduit Pipe Coil (Blue) 22mm x 25 metre Conduit Pipe Coil (Blue) 22mm x 50 metre Conduit Pipe Coil (Blue)</p>	<p>1 1 1 1 1 1 1 1 1 1 1 1</p>	<p>CPC1525 CPC1550 CPC2225 CPC2250 CPC1525R CPC1550R CPC2225R CPC2250R CPC1525BU CPC1550BU CPC2225BU CPC2250BU</p>	

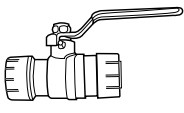
COMPONENT	PRODUCT DESCRIPTION	PACK QUANTITY	CODE NUMBER
	Straight Coupler 10mm Straight Coupler 15mm Straight Coupler 22mm Straight Coupler 28mm Straight Coupler	10 10 10 10	PB010 PB015 PB022 PB028
	Elbow 10mm Elbow 15mm Elbow 22mm Elbow 28mm Elbow	10 10 10 10	PB110 PB115 PB122 PB128
	Spigot Elbow 10mm Spigot Elbow 10mm x 15mm Spigot Elbow 15mm Spigot Elbow 22mm Spigot Elbow (not suitable for use with compression fittings)	10 10 10 10	PB1010 PB101510 PB1015 PB1022
	Female Elbow (Brass) 15mm x 1/2" 22mm x 1/2" 22mm x 3/4"	5 5 5	PB3015 PB302212 PB3022
	Use PTFE tape to seal threads		
	Equal Tee 10mm Equal Tee 15mm Equal Tee 22mm Equal Tee 28mm Equal Tee	10 10 10 10	PB210 PB215 PB222 PB228
	End Reduced Tee 15mm x 10mm x 15mm End Reduced Tee 22mm x 15mm x 22mm End Reduced Tee 28mm x 22mm x 28mm End Reduced Tee	5 5 5	PB1415 PB1422 PB1428
	Branch Reduced Tee 15mm x 15mm x 10mm Branch Reduced Tee 22mm x 22mm x 10mm Branch Reduced Tee 22mm x 22mm x 15mm Branch Reduced Tee 28mm x 28mm x 22mm Branch Reduced Tee	5 5 5 5	PB1115 PB112210 PB1122 PB1128
	Branch Reduced Spigot Tee 15mm x 15mm x 10mm Branch Reduced Spigot Tee 22mm x 22mm x 15mm Branch Reduced Spigot Tee (not suitable for use with compression fittings)	5 5	PB1215 PB1222
	Branch and one End Reduced Tee 15mm x 10mm x 10mm Branch & 1 End Reduced Tee 22mm x 15mm x 15mm Branch & 1 End Reduced Tee 28mm x 22mm x 22mm Branch & 1 End Reduced Tee	5 5 5	PB1515 PB1522 PB1528
	Two Ends Reduced Tee 15mm x 15mm x 22mm 2 Ends Reduced Tee	5	PB1622
	Female Tee (Brass) 15mm x 1/2" 22mm x 1/2"	5 5	PB2915 PB292212
	Use PTFE tape to seal threads		

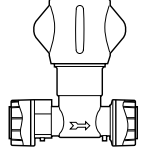
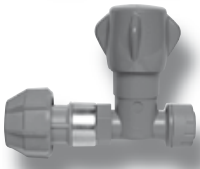
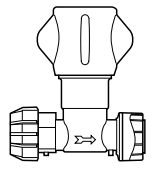
COMPONENT	PRODUCT DESCRIPTION	PACK QUANTITY	CODE NUMBER	
	Spigot Reducer 15mm x 10mm Spigot Reducer 22mm x 15mm Spigot Reducer (not suitable for use with compression fittings) 28mm x 22mm Spigot Reducer (not suitable for use with compression fittings)	5 5 5	PB815 PB822 PB828	
	Socket Reducer 15mm x 10mm Socket Reducer 22mm x 15mm Socket Reducer (not suitable for use with compression fittings) 28mm x 22mm Socket Reducer (not suitable for use with compression fittings)	10 10 10	PB1815 PB1822 PB1828	
	Reducing Coupling 22mm x 10mm Socket Reducer	5	PB582210	
	Tank Connector (cold water only) 15mm x 1/2" Tank Connector 22mm x 3/4" Tank Connector 28mm x 1" Tank Connector Complete with E.P.D.M. Sealing Washer (tighten by hand)	10 10 10	PB3815 PB3822 PB3828	
	Straight Tap Connector (Brass Connecting Nut) 15mm x 1/2" Straight Tap Connector 15mm x 3/4" Straight Tap Connector 22mm x 3/4" Straight Tap Connector Spare flat seal included Complete with E.P.D.M. Sealing Washer (tighten by hand plus quarter turn with spanner)	10 5 5	PB715 PB71534 PB722	
	Hand Tighten Tap Connector (not suitable for central heating) 15mm x 1/2" Hand Tighten Tap Connector 15mm x 3/4" Hand Tighten Connector 22mm x 3/4" Hand Tighten Connector Complete with E.P.D.M. Sealing Washer	10 5 5	PB2715 PB271534 PB2722	
	Bent Tap Connector (Brass Connecting Nut) 15mm x 1/2" Bent Tap Connector Spare flat seal included Complete with E.P.D.M. Sealing Washer (tighten by hand plus quarter turn with spanner)	10	PB1715	
	Flexible Hose Tap Connectors (not suitable for central heating) 10mm x 1/2" Flexible Tap Connector 15mm x 1/2" Flexible Tap Connector 15mm x 3/4" Flexible Tap Connector 22mm x 3/4" Flexible Tap Connector	2 2 2 2	PB681012 PB6815 PB681534 PB6822	
	Male BSP Adaptor (DZR Brass Body) 10mm x 1/4" MBSP Adaptor 10mm x 3/8" MBSP Adaptor 15mm x 1/2" MBSP Adaptor 22mm x 3/4" MBSP Adaptor 28mm x 1" MBSP Adaptor	10 10 10 10 10	PB4310 PB431038 PB4315 PB4322 PB4328	<div style="border: 1px solid black; padding: 5px; width: fit-content;"> Taper BSP threads to BS21 only use PTFE tape to seal threads </div> 
	Female BSP Adaptor (DZR Brass Body) 10mm x 1/4" Female BSP Adaptor 10mm x 3/8" Female BSP Adaptor 15mm x 1/2" Female BSP Adaptor 15mm x 3/4" Female BSP Adaptor 22mm x 3/4" Female BSP Adaptor 28mm x 1" Female BSP Adaptor	10 10 10 10 10 10	PB4410 PB441038 PB4415 PB441534 PB4422 PB4428	<div style="border: 1px solid black; padding: 5px; width: fit-content;"> Parallel BSP threads to BS21 only use PTFE tape to seal threads </div> 

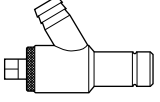

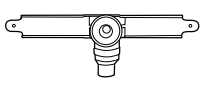







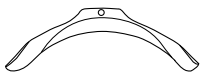



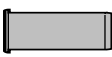



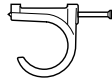

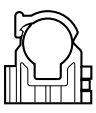
COMPONENT	PRODUCT DESCRIPTION	PACK QUANTITY	CODE NUMBER
	<p>MDPE Polyfast Adaptor (cold water only)</p> <p>15mm x 20mm MDPE Adaptor 15mm x 25mm MDPE Adaptor 22mm x 25mm MDPE Adaptor 22mm x 32mm MDPE Adaptor 28mm x 32mm MDPE Adaptor</p>	<p>All include MDPE 12 Bar Plastic Pipe Stiffener</p> <p>5 5 5 5 5</p>	<p>PB422015 PB422515 PB422522 PB423222 PB423228</p> 
	<p>Gate Valve (Brass)</p> <p>15mm Gate Valve 22mm Gate Valve</p>	<p>5 5</p>	<p>PB3115 PB3122</p> 
	<p>Thermostatic Radiator Valve (Plated Brass)</p> <p>10mm Thermostatic Radiator Valve 15mm Thermostatic Radiator Valve</p>	<p>Use PTFE tape to seal threads</p> <p>1 1</p>	<p>PB3310 PB3315</p> 
	<p>Radiator/Lockshield Valve (Plated Brass)</p> <p>10mm Radiator Valve 15mm Radiator Valve</p>	<p>Use PTFE tape to seal threads</p> <p>1 1</p>	<p>PB3210 PB3215</p> 
	<p>Radiator Connector (Bend "RCB")</p> <p>10mm Radiator Connector Bend 15mm Radiator Connector Bend</p>	<p>Pipe stiffeners must be used on each end</p> <p>10 10</p>	<p>PB3910 PB3915</p> 
	<p>Radiator Terminal Plate</p> <p>Radiator Terminal Plate</p>	<p>10</p>	<p>RTP10</p> 
	<p>Spigot Blank Ends</p> <p>10mm Spigot Blank End 15mm Spigot Blank End 22mm Spigot Blank End (not suitable for use with compression fittings) 28mm Spigot Blank End (not suitable for use with compression fittings)</p>	<p>10 10 10 10</p>	<p>PB910 PB915 PB922 PB928</p> 
	<p>Socket Blank Ends</p> <p>10mm Socket Blank End 15mm Socket Blank End 22mm Socket Blank End 28mm Socket Blank End</p>	<p>10 10 10 10</p>	<p>PB1910 PB1915 PB1922 PB1928</p> 

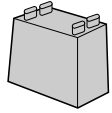
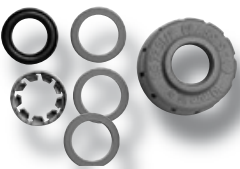
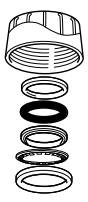







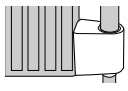

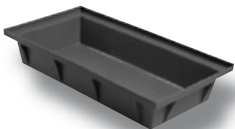
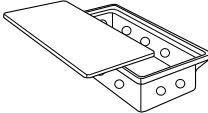



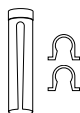

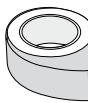

COMPONENT	PRODUCT DESCRIPTION	PACK QUANTITY	CODE NUMBER	
	Demountable Socket Blank Ends 10mm Demountable Socket Blank End 15mm Demountable Socket Blank End 22mm Demountable Socket Blank End 28mm Demountable Socket Blank End	10 10 10 10	PB6910 PB6915 PB6922 PB6928	
	Shut-Off Valve (not suitable for central heating) 15mm x 15mm Shut-Off Valve - Warm/Cold (Please note these valves now contain a plain white index)	5	PB5915	
	Appliance Valve (not suitable for central heating) 15mm x 3/4" Appliance Valve - Warm/Cold (Please note these valves now contain a plain white index)	5	PB6115	
	Straight Service Valve (not suitable for central heating) 15mm x 1/2" Straight Service Valve	5	PB6515	
	Bent Service Valve (not suitable for central heating) 15mm x 1/2" 90° Bent Service Valve	5	PB6615	
	Bent Service Valves (not suitable for central heating) 15mm x 15mm 90° Bent Service Valve (Please note these valves now contain a plain white index)	5	PB7915	
	Double Check Valve (not suitable for central heating) 15mm Double Check Valve 22mm Double Check Valve 28mm Double Check Valve	1 1 1	PB3715 PB3722 PB3728	
	Quarter Turn Ball Valve (Nickel Plated Brass) 15mm Quarter Turn Ball Valve 22mm Quarter Turn Ball Valve 28mm Quarter Turn Ball Valve	5 2 2	PB6715 PB6722 PB6728	
	Stopcock (cold water only) 15mm x 15mm Stopcock 22mm x 22mm Stopcock	5 5	PB2615 PB2622	
	MDPE Stopcocks (Polyfast) (cold water only) 20mm MDPE x 15mm Polyfast Stopcock 25mm MDPE x 15mm Polyfast Stopcock 25mm MDPE x 22mm Polyfast Stopcock	5 5 5	PB262015 PB262515 PB262522	
	Spigot Draincock (Brass) 15mm Spigot Draincock	10	PB3615	
	Conduit Terminal Box Conduit Terminal Box including 15mm x 1/2" Wall Plate Elbow Conduit Terminal Box Wall Plate	2 10	PB4515 CTWP	

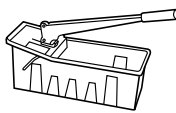
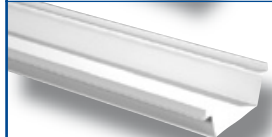
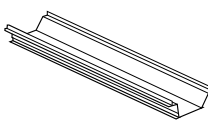
COMPONENT	PRODUCT DESCRIPTION	PACK QUANTITY	CODE NUMBER
	Wall Plate Elbow (Brass) 15mm x 1/2" BSP Wall Plate Elbow	5	PB1315
	22mm x 1/2" BSP Wall Plate Elbow	5	PB132212
	28mm x 1/2" BSP Wall Plate Elbow	5	PB132812
	Wall Plate Elbow (Plastic) (cold water only) 15mm x 1/2" BSP Wall Plate Elbow	5	PB5315
	22mm x 1/2" BSP Wall Plate Elbow	5	PB532212
	22mm x 3/4" BSP Wall Plate Elbow	5	PB5322
	Wall Plate Tee (Brass) 15mm x 1/2" BSP Wall Plate Tee	5	PB5115
	22mm x 1/2" BSP Wall Plate Tee	5	PB512212

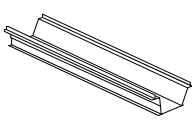
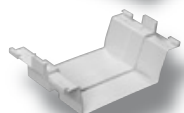
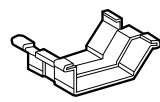
POLYPLUMB MANIFOLD SYSTEM

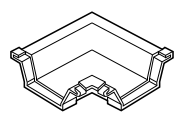
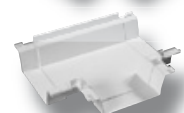
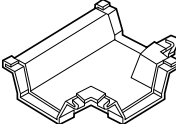
	Polybutylene Double Sided Manifold 22mm x 10mm – 2 Port (Socket/Socket)	5	PB2822	
	22mm x 10mm – 4 Port (Socket/Socket)	5	PB4822	
	22mm x 10mm – 4 Port (Socket/Spigot)	5	PB4922	
	(use Ball Valve to convert to Valved Manifold)			
	Polybutylene Single Sided Manifold 22mm x 15mm – 3 Port (Socket/Socket)	5	PB7322153	
	22mm x 15mm – 3 Port (Socket/Spigot)	5	PB7622153	
	22mm x 10mm – 4 Port (Socket/Socket)	5	PB7322104	
	22mm x 10mm – 4 Port (Socket/Spigot)	5	PB7622104	
		(use Ball Valve to convert to Valved Manifold)		
	Brass Single Sided Manifold Unvalved (Brass) 15mm x 3/4" Female/Male BSP 2 Port	1	PB47152	
	15mm x 3/4" Female/Male BSP 3 Port	1	PB47153	
	Brass Single Sided Manifold Valved (Brass) 15mm x 3/4" Female/Male BSP 2 Port	1	PB5234152	
	15mm x 3/4" Female/Male BSP 3 Port	1	PB5234153	
	Ball Valve (Brass) 15mm x 15mm Ball Valve – (Socket/Spigot)	5	PB4015	
	(use to convert Unvalved to Valved version)			
	Manifold Bracket (Metal) 3/4" Manifold Bracket	2	PB4634	

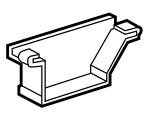
COMPONENT	PRODUCT DESCRIPTION		PACK QUANTITY	CODE NUMBER	
	Bend Former 15mm Bend Former 22mm Bend Former	Bend radius is 8 x Pipe diameter	5 5	PB6315 PB6322	
	Pipe Stiffener (Plastic) 10mm Pipe Stiffener 15mm Pipe Stiffener 22mm Pipe Stiffener 28mm Pipe Stiffener	Must be used with Polybutylene pipe	20 50 50 20	PB6410 PB6415 PB6422 PB6428	
	Pipe Stiffener (Stainless Steel) 10mm Pipe Stiffener 15mm Pipe Stiffener 22mm Pipe Stiffener		20 50 50	PB6410M PB6415M PB6422M	
	Bulldog Clips (Polypropylene) 15mm Bulldog Clip 22mm Bulldog Clip 28mm Bulldog Clip		50 50 50	PB2115 PB2122 PB2128	
	Nail-In Clips (Polypropylene) 10mm Nail-In Clip 15mm Nail-In Clip 22mm Nail-In Clip 28mm Nail-In Clip		50 50 50 50	PB2210 PB2215 PB2222 PB2228	
	Snap-Fit Clips (Polypropylene) 10mm Snap-Fit Clip 15mm Snap-Fit Clip 22mm Snap-Fit Clip 28mm Snap-Fit Clip		50 50 50 50	PB2310 PB2315 PB2322 PB2328	
	Pipe Clip Spacer (Polypropylene) 10mm Pipe Clip Spacer 15mm Pipe Clip Spacer 22mm Pipe Clip Spacer 28mm Pipe Clip Spacer		20 20 20 20	PB2410 PB2415 PB2422 PB2428	
	Spares Component Kit 10mm Spares Component Kit 15mm Spares Component Kit 22mm Spares Component Kit 28mm Spares Component Kit 15mm Component Pack for Ireland Specification		10 10 10 10 10	PB9510 PB9515 PB9522 PB9528 IPB9515	
	Conical E.P.D.M. Sealing Washer (for Tap Connector with brass nut) 1/2" Sealing Washer 3/4" Sealing Washer		20 20	PB9312 PB9334	
	Flat E.P.D.M. Sealing Washer (for Hand Tighten Tap Connector) 1/2" Sealing Washer 3/4" Sealing Washer		20 20	PB9412 PB9434	
	'O' Rings EPDM Rubber (must be lubricated before use with Silicone Lubricant) 3/4" 'O' Ring		20	PB9034	
	Valve Tidy Cover (Polypropylene) Radiator Valve Cover Complete with Pipe Adaptors for 10mm/8mm pipe		6	VT149	

COMPONENT	PRODUCT DESCRIPTION	PACK QUANTITY	CODE NUMBER	
	Junction Inspection Box (Polypropylene) Junction Box (75mm deep - grey) Junction Box Lid (12mm plywood) Junction Box (65mm deep - black)	1 1 1	JIB1 JIB2 JIB3	
	Silicone Lubricant, Solvent Cement and Cleaning Fluid Silicone Lubricant 250ml Solvent Cement 125ml Solvent Cement 250ml Solvent Cement 500ml Cleaning Fluid 250ml	10 10 10 10 10	9136.250 9100.125 9100.250 9100.500 9101.250	
	Boiler Overflow Pipe Guard Boiler Overflow Pipe Guard (Pipe Guard comes with x 2 Pipe Clips)	1	BOPG50	
	Self Adhesive Aluminium Tape 48mm wide x 46 metres long (do not stick to Polyplumb pipes)	24	ALTP	
	Pipe Cutters Standard V Bladed Standard Cutter 10mm to 22mm Pipe Cutters Ratchet Ratchet Type Cutters Replacement Blade for Ratchet Cutter	1 1 1	PB781 PB778 PB779	 
	System Test Kit Polyplumb System Test Kit	1	PB993	
	Under Floor Pipe Duct (PVCu) 50mm depth x 150mm width x 3 metre For 10, 15 & 22mm Pipe (requires 12mm thickness Cover Board)	5	FD50	
	Under Floor Pipe Duct (PVCu) 70mm depth x 150mm width x 3 metre For 28mm Pipe, Duct only - fittings fabricated on site (requires 12mm Cover Board)	5	FD70	
	Push-Fit Union (PVCu) Double Socket for 50mm only	10	FD52	
	Push-Fit 90° Angle (PVCu) Double Socket for 50mm only	10	FD53	
	Push-Fit 90° Tee (PVCu) Triple Socket for 50mm only	10	FD54	
	Push-Fit End Cap (PVCu) Single Socket for 50mm only (insert Solvent Weld pipe clips and base)	10	FD55	
	Solvent Weld Pipe Clips (for use with PVCu Pipe Duct) 15mm (ABS) 22mm (ABS) 28mm (ABS) Pipe Clip Base Plate (PVC)	10 10 10 10	FDB15 FDB22 FDB28 FDB9	

POLYFIT SYSTEM

POLYFIT



Polyfit is the one step, fully demountable and reusable pushfit plumbing product, which combines with white polybutylene pipe to create a truly flexible, yet highly secure, plumbing system that is demountable and reusable when required.

The Polyfit system brings extensive benefits:

- One step operation, for quick and easy installation
- Flexible polybutylene pipe, for even the most difficult locations
- Fittings lock tight, preventing accidental release
- Fully demountable and re-usable when required

'Push click', that's it

The polybutylene pipe is simply inserted into the Polyfit fitting to engage. There's no need to make a quarter locking turn, just 'push click', that's it.

Locked tight

Polyfit fittings lock tight in one click and can only be released when required, providing both installers and consumers with total piece of mind. Once engaged into the fitting it is completely secure against accidental release.

Fully demountable

Polyfit fittings have been designed to be completely secure once installed. However, there will always be times when they need to be removed or adjusted, so they are also fully demountable when required.

Joining

There are four stages to successfully joining the Polyfit system.

Cutting Polyfit pipes

Step 1:

Firstly check that the pipe is not scored or scratched in any way and if it is so cut back to a point where there is no damage present.

Using an approved pipe cutter cut the pipe squarely using the "K" marks on the pipe as a guide.



Use of pipe stiffener

Step 2:

Insert a pipe stiffener into the pipe (not required on copper pipes).



Inserting pipe into fitting

Step 3:

Push pipe into the fitting, ensuring it is inserted to the full socket depth denoted by the next "K" mark on the pipe.

Insertion depth markers on fittings

Each fitting now has an insertion depth marker on the fitting body to aid with installation. The only way of being certain that a joint has been completed successfully is by using the insertion depth marks on the pipe for cutting and insertion purposes.



Checking the joint security

Step 4:

Tug back on pipe to check it is inserted fully.



Connecting Polyfit to copper pipes

Cut the copper pipe using a rotational pipe cutter. Mark the copper pipe insertion depth as shown in the table below. Follow steps 3 and 4 using the mark as a socket depth guide.

Insertion Depth				
Pipe diameter (mm)	10	15	22	28
Insertion depth (mm)	25	35	42	44





Demounting a Polyfit joint

Polyfit fittings are fully demountable and re-usable. To demount a Polyfit fitting simply depress the collet squarely towards the fitting and pull the pipe out of the fitting. When systems have been pressurised the collet is designed to grip into the pipe therefore using a fitting release aid (product code FITAID) will assist in demounting fittings.



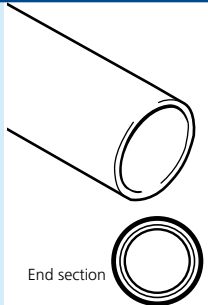

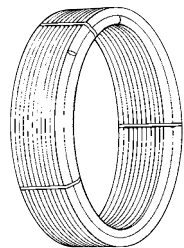

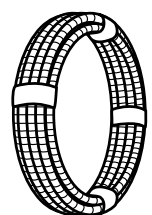



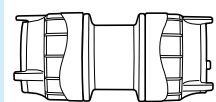

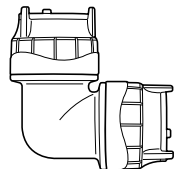

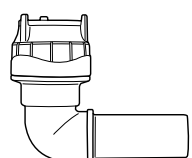



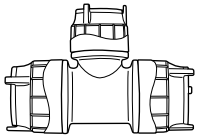

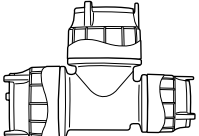

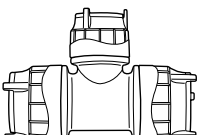

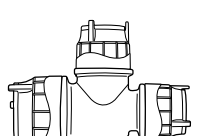

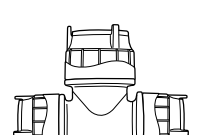
System testing

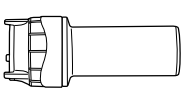

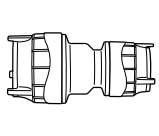

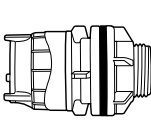

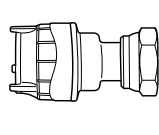
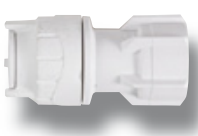
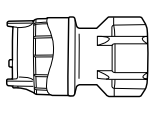

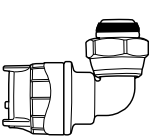

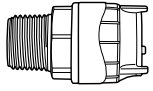

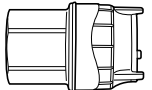

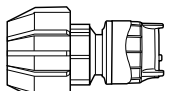

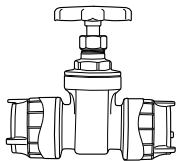

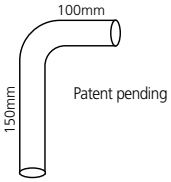

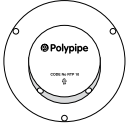
Prior to completing installation it is necessary to fully test the installed system. Please refer to the section on page 46 of this Product Guide for system testing guidance.

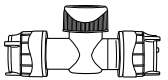
COMPONENT	PRODUCT DESCRIPTION	PACK QUANTITY	CODE NUMBER	
	Barrier Polybutylene Pipe Cut Length 15mm x 2 metre Cut Length 15mm x 3 metre Cut Length 15mm x 6 metre Cut Length 22mm x 2 metre Cut Length 22mm x 3 metre Cut Length 22mm x 6 metre Cut Length 28mm x 3 metre Cut Length 28mm x 6 metre Cut Length	10 10 10 10 10 10 10 10	FIT215B FIT315B FIT615B FIT222B FIT322B FIT622B FIT328B FIT628B	
	Barrier Polybutylene Pipe Coils (featuring "Plumb Straight" Coiling Technology) 10mm x 25 metre Coil 10mm x 50 metre Coil 10mm x 100 metre Coil 15mm x 25 metre Coil 15mm x 50 metre Coil 15mm x 100 metre Coil 15mm x 120 metre Coil 15mm x 150 metre Coil 22mm x 25 metre Coil 22mm x 50 metre Coil 28mm x 25 metre Coil 28mm x 50 metre Coil	1 1 1 1 1 1 1 1 1 1 1 1 1 1	FIT2510B FIT5010B FIT10010B FIT2515B FIT5015B FIT10015B FIT12015B FIT15015B FIT2522B FIT5022B FIT2528B FIT5028B	
	Conduit Pipe Coils (Polypropylene) 15mm x 25 metre Conduit Pipe Coil (Black) 15mm x 50 metre Conduit Pipe Coil (Black) 22mm x 25 metre Conduit Pipe Coil (Black) 22mm x 50 metre Conduit Pipe Coil (Black) 15mm x 25 metre Conduit Pipe Coil (Red) 15mm x 50 metre Conduit Pipe Coil (Red) 22mm x 25 metre Conduit Pipe Coil (Red) 22mm x 50 metre Conduit Pipe Coil (Red) 15mm x 25 metre Conduit Pipe Coil (Blue) 15mm x 50 metre Conduit Pipe Coil (Blue) 22mm x 25 metre Conduit Pipe Coil (Blue) 22mm x 50 metre Conduit Pipe Coil (Blue)	1 1 1 1 1 1 1 1 1 1 1 1 1	CPC1525 CPC1550 CPC2225 CPC2250 CPC1525R CPC1550R CPC2225R CPC2250R CPC1525BU CPC1550BU CPC2225BU CPC2250BU	

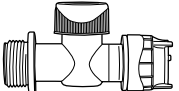
POLYFIT FITTINGS

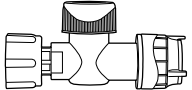

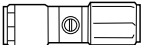

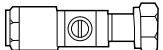



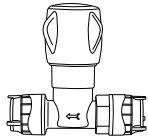
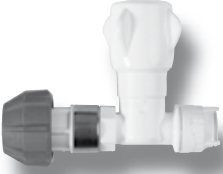
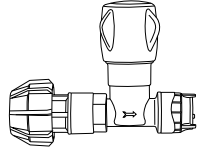

COMPONENT	PRODUCT DESCRIPTION	PACK QUANTITY	CODE NUMBER	
	Straight Coupler 10mm Straight Coupler 15mm Straight Coupler 22mm Straight Coupler 28mm Straight Coupler	10 10 10 10	FIT010 FIT015 FIT022 FIT028	
	Elbow 10mm Elbow 15mm Elbow 22mm Elbow 28mm Elbow	10 10 10 10	FIT110 FIT115 FIT122 FIT128	
	Spigot Elbow 10mm Spigot Elbow 10mm x 15mm Spigot Elbow 15mm Spigot Elbow 22mm Spigot Elbow (not suitable for use with compression fittings)	10 10 10 10	FIT1010 FIT101510 FIT1015 FIT1022	

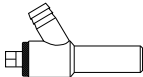
COMPONENT	PRODUCT DESCRIPTION	PACK QUANTITY	CODE NUMBER	
	Equal Tee 10mm Equal Tee 15mm Equal Tee 22mm Equal Tee 28mm Equal Tee	10 10 10 10	FIT210 FIT215 FIT222 FIT228	
	End Reduced Tee 15mm x 10mm x 15mm End Reduced Tee 22mm x 15mm x 22mm End Reduced Tee 28mm x 22mm x 28mm End Reduced Tee	5 5 5	FIT1415 FIT1422 FIT1428	
	Branch Reduced Tee 15mm x 15mm x 10mm Branch Reduced Tee 22mm x 22mm x 10mm Branch Reduced Tee 22mm x 22mm x 15mm Branch Reduced Tee 28mm x 28mm x 22mm Branch Reduced Tee	5 5 5 5	FIT1115 FIT112210 FIT1122 FIT1128	
	Branch and one End Reduced Tee 15mm x 10mm x 10mm Branch & One End Reduced Tee 22mm x 15mm x 15mm Branch & 1 End Reduced Tee 28mm x 22mm x 22mm Branch & One End Reduced Tee	5 5 5	FIT1515 FIT1522 FIT1528	
	Two Ends Reduced Tee 15mm x 15mm x 22mm 2 End Reduced Tee	5	FIT1622	
	Socket Reducer 15mm x 10mm Socket Reducer 22mm x 15mm Socket Reducer (not suitable for use with compression fittings) 28mm x 15mm Socket Reducer (not suitable for use with compression fittings) 28mm x 22mm Socket Reducer (not suitable for use with compression fittings)	10 10 10 10	FIT1815 FIT1822 FIT182815 FIT1828	
	Reducing Coupler 15mm x 10mm Reducing Coupler 22mm x 10mm Reducing Coupler 22mm x 15mm Reducing Coupler	5 5 5	FIT5815 FIT582210 FIT5822	
	Tank Connector (cold water only) 15mm x 1/2" Tank Connector 22mm x 3/4" Tank Connector Complete with E.P.D.M. Sealing Washer (tighten by hand)	10 10	FIT3815 FIT3822	
	Straight Tap Connector (Brass Connecting Nut) 15mm x 1/2" Straight Tap Connector 15mm x 3/4" Straight Tap Connector 22mm x 3/4" Straight Tap Connector Complete with E.P.D.M. Sealing Washer (tighten by hand plus quarter turn with spanner)	10 5 5	FIT715 FIT71534 FIT722	
	Hand Tighten Tap Connector (not suitable for central heating) 10mm x 1/2" Hand Tighten Tap Connector 15mm x 1/2" Hand Tighten Tap Connector 15mm x 3/4" Hand Tighten Tap Connector 22mm x 3/4" Hand Tighten Tap Connector Complete with E.P.D.M. Sealing Washer	10 10 5 5	FIT271012 FIT2715 FIT271534 FIT2722	
	Bent Tap Connector (Brass Connecting Nut) 15mm x 1/2" Bent Tap Connector Complete with E.P.D.M. Sealing Washer (tighten by hand plus quarter turn with spanner)	10	FIT1715	

COMPONENT	PRODUCT DESCRIPTION	PACK QUANTITY	CODE NUMBER	
	Male BSPT Adaptor (DZR Brass Body) 10mm x 1/2" Male BSPT Adaptor 15mm x 1/2" Male BSPT Adaptor 22mm x 3/4" Male BSPT Adaptor 28mm x 1" Male BSPT Adaptor	Taper BSP threads to BS21. Only use PTFE tape to seal threads 10 10 10 10	FIT431012 FIT4315 FIT4322 FIT4328	
	Female BSP Adaptor (DZR Brass Body) 10mm x 1/2" Female BSP Adaptor 15mm x 1/2" Female BSP Adaptor 22mm x 3/4" Female BSP Adaptor	Parallel BSP threads to BS21. Only use PTFE tape to seal threads 10 10 10	FIT441012 FIT4415 FIT4422	
	MDPE x PolyFit Adaptor (cold water only) 20mm x 15mm MDPE x PolyFit Adaptor 25mm x 15mm MDPE x PolyFit Adaptor 25mm x 22mm MDPE x PolyFit Adaptor	5 5 5	FIT422015 FIT422515 FIT422522	
	Gate Valve 15mm Gate Valve 22mm Gate Valve	5 5	FIT3115 FIT3122	
	Radiator Connector Bend "RCB" (Pipe Stiffeners must be used on each end) 10mm Radiator Connector Bend 15mm Radiator Connector Bend	10 10	PB3910 PB3915	 Patent pending
	Radiator Terminal Plate Radiator Terminal Plate	10	RTP10	
	Shut-Off Valve (not suitable for central heating) 15mm x 15mm Shut-Off Valve Warm/Cold (Please note these valves now contain a plain white index)	5	FIT5915	
	Appliance Valve (not suitable for central heating) 15mm x 3/4" Appliance Valve Warm/Cold (Please note these valves now contain a plain white index)	5	FIT6115	
	Service Valve (not suitable for central heating) 15mm x 1/2" Straight Service Valve (Please note these valves now contain a plain white index)	5	FIT6515	
	Chrome Plated Service Valve (Brass) 15mm x 15mm Brass c/p Service Valve 22mm x 22mm Brass c/p Service Valve	5 5	FIT8515 FIT8522	
	Chrome Plated Service Valve with Tap Connector (Brass) 15mm x 1/2" Brass c/p Service Valve 22mm x 3/4" Brass c/p Service Valve	5 5	FIT8615 FIT8622	

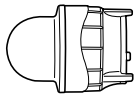

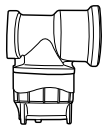

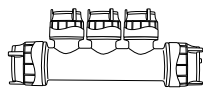
POLYFIT FITTINGS





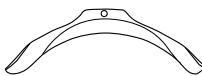





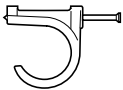

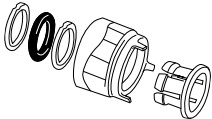

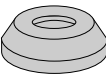
POLYFIT

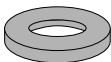
COMPONENT	PRODUCT DESCRIPTION	PACK QUANTITY	CODE NUMBER	
	Stopcock (cold water only) 15mm x 15mm Stopcock 22mm x 22mm Stopcock	5 5	FIT2615 FIT2622	
	MDPE Stopcock (cold water only) 20mm MDPE x 15mm Polyfit Stopcock 25mm MDPE x 22mm Polyfit Stopcock	5 5	FIT262015 FIT262522	
	Spigot Draincock (Brass) 15mm Spigot Draincock	10	FIT3615	
	Spigot Blank Ends (not suitable for use with compression fittings) 10mm Spigot Blank End 15mm Spigot Blank End 22mm Spigot Blank End (with reinforcing sleeve)	10 10 10	FIT910 FIT915 FIT922	
	Socket Blank Ends 10mm Socket Blank End 15mm Socket Blank End 22mm Socket Blank End 28mm Socket Blank End	10 10 10 10	FIT1910 FIT1915 FIT1922 FIT1928	
	Wall Plate Elbow (Brass) 15mm x 1/2" BSP Wall Plate Elbow	5	FIT1315	
				Use PTFE Tape to seal threads
	Polybutylene Double Sided Manifold 22mm x 10mm – 2 Port (Socket/Socket) 22mm x 10mm – 4 Port (Socket/Socket)	5 5	FIT2822 FIT4822	
	Polybutylene Single Sided Manifold 22mm x 10mm – 4 Port (Socket/Socket) 22mm x 15mm – 3 Port (Socket/Socket)	5 5	FIT7322104 FIT7322153	

POLYFIT ANCILLARIES

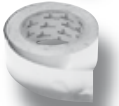
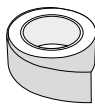
POLYFIT

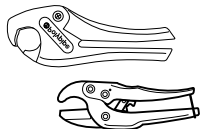
COMPONENT	PRODUCT DESCRIPTION	PACK QUANTITY	CODE NUMBER	
	Bend Former 15mm Bend Former 22mm Bend Former (bend radius is 8 x pipe diameter)	5 5	PB6315 PB6322	
	Pipe Stiffener (Plastic) 10mm Pipe Stiffener 15mm Pipe Stiffener 22mm Pipe Stiffener 28mm Pipe Stiffener (must be used with Polybutylene pipe)	20 50 50 20	PB6410 PB6415 PB6422 PB6428	
	Pipe Stiffener (Stainless Steel) 10mm Pipe Stiffener 15mm Pipe Stiffener 22mm Pipe Stiffener (must be used with Polybutylene pipe)	20 50 50	PB6410M PB6415M PB6422M	

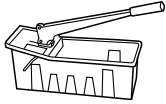
COMPONENT	PRODUCT DESCRIPTION	PACK QUANTITY	CODE NUMBER	
	Nail-In Clips (Polypropylene) 10mm Nail-In Clip 15mm Nail-In Clip 22mm Nail-In Clip 28mm Nail-In Clip	50 50 50 50	FIT2210 FIT2215 FIT2222 FIT2228	
	Spares Component Kit 10mm Spares Component Kit 15mm Spares Component Kit 22mm Spares Component Kit 28mm Spares Component Kit	10 10 10 10	FIT9510 FIT9515 FIT9522 FIT9528	
	Conical E.P.D.M. Sealing Washer For Tap Connector with Brass Nut 1/2" Sealing Washer 3/4" Sealing Washer	20 20	PB9312 PB9334	
	Flat E.P.D.M. Sealing Washer For Hand Tighten Tap Connector 1/2" Sealing Washer 3/4" Sealing Washer	20 20	PB9412 PB9434	
	'O'-Rings (EPDM Rubber) 3/4" 'O'Ring (must be lubricated before use with Silicone Lubricant)	20	PB9034	
	PolyFit Fitting Release Aid Set of 4 for 10mm, 15mm, 22mm and 28mm fittings, a useful tool to assist in demounting PolyFit fittings, but not essential	Per Set	FITAID	
	Self Adhesive Aluminium Tape 48mm wide x 46 metres long (do not stick to Polyfit pipes)	24	ALTP	
	Pipe Cutters V Bladed Standard Type Cutter 10mm to 22mm Pipe Cutters Ratchet Ratchet Type Cutters Replacement Blade for Ratchet Cutter	1 1 1	PB781 PB778 PB779	
	System Test Kit System Test Kit	1	PB993	

POLYFIT FLEXIBLE CONNECTORS

Flexible hose connectors are the latest great addition to the Polyfit product range. This versatile collection comes in a wide range of length and connection end combinations to suit every need. Many of our flexible connectors include the Polyfit one step joint feature, which are quick and easy to install and are ideal for use in tricky to reach or tight locations.

- All Polyfit hoses which have a tap connector nut now contain captive rubber seals ensuring that seals are not lost or damaged on site.

- All Polyfit flexible connectors are listed under the Water Regulations Advisory Scheme. Look out for the black thread that is wound into each hose, which denotes a WRAS quality product. Each EPDM hose is suitable for use in domestic hot and cold water applications and must not be used for heating applications.
- Polyfit flexible hoses come in a packaging design which aids quick and easy product selection and all hoses come in pairs.

Selecting your Polyfit Flexible Connector

Polyfit Fitting 15mm and 22mm

Polyfit push fit connections. Just push, click, Polyfit ends are secure in use but also fully demountable and reusable.



Polyfit Chrome Plated Valve 15mm and 22mm

Connectors incorporating service valves to reduce the number of joints within a system. Incorporates the Polyfit push fit feature.



Tap Connection Nut 1/2" and 3/4"

These "wing nut" style tap connector nuts will only require hand tightening.







Compression Fitting 15mm and 22mm



































Our compression end connectors use the same high quality components as the rest of the Polyfit push fit range.









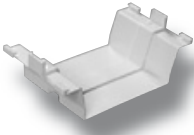

POLYFIT FITTINGS

POLYFIT

COMPONENT	PRODUCT DESCRIPTION	PACK QUANTITY	CODE NUMBER
	Flexible Hose Tap Connector - 150mm long (not suitable for central heating) 15mm x 1/2" Flexible Hose Tap Connector	2	FIT5715
	Flexible Hose Tap Connector - 300mm long (not suitable for central heating) 15mm x 1/2" Flexible Hose Tap Connector 15mm x 3/4" Flexible Hose Tap Connector 22mm x 3/4" Flexible Hose Tap Connector	2 2 2	FIT6815 FIT681534 FIT6822
	Flexible Hose Tap Connector - 500mm long (not suitable for central heating) 15mm x 1/2" Flexible Hose Tap Connector 15mm x 3/4" Flexible Hose Tap Connector 22mm x 3/4" Flexible Hose Tap Connector	2 2 2	FIT8315 FIT831534 FIT8322
	Flexible Hose Tap Connector - 1000mm long (not suitable for central heating) 15mm x 1/2" Flexible Hose Tap Connector 15mm x 3/4" Flexible Hose Tap Connector 22mm x 3/4" Flexible Hose Tap Connector	2 2 2	FIT8015 FIT801534 FIT8022

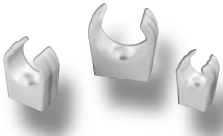
COMPONENT		PRODUCT DESCRIPTION	PACK QUANTITY	CODE NUMBER	
		Flexible Hose Tap Connector with Service Valve - 300mm long (not suitable for central heating) 15mm x 1/2" Flexible Hose Tap Connector 22mm x 3/4" Flexible Hose Tap Connector	2 2	FIT8415 FIT8422	
		Flexible Hose Tap Connector with Service Valve - 500mm long (not suitable for central heating) 15mm x 1/2" Flexible Hose Tap Connector 22mm x 3/4" Flexible Hose Tap Connector	2 2	FIT8715 FIT871534	
		Flexible Polyfit Connector with Service Valve - 300mm long (not suitable for central heating) 15mm x 15mm Flexible Polyfit Connector	2	FIT8815	
		Flexible Polyfit Connector with Service Valve - 500mm long (not suitable for central heating) 15mm x 15mm Flexible Polyfit Connector	2	FIT8915	
		Flexible Polyfit Connector - 300mm long (not suitable for central heating) 15mm x 15mm Flexible Polyfit Connector 22mm x 22mm Flexible Polyfit Connector	2 2	FIT8115 FIT8122	
		Flexible Polyfit Connector - 500mm long (not suitable for central heating) 15mm x 15mm Flexible Polyfit Connector 22mm x 22mm Flexible Polyfit Connector	2 2	FIT8215 FIT8222	
		Monobloc Mixer Tap Flexible Connector - 300mm long (not suitable for central heating) 15mm x M10 Flexible Polyfit Connector 15mm x M12 Flexible Polyfit Connector (supplied in pairs with offset nuts to aid installation to mixer tap)	Set of 2 Set of 2	FIT7515M10 FIT7515M12	 
		Compression Flexible Hose Tap Connector - 300mm long (not suitable for central heating) 15mm x 1/2" Flexible Hose Tap Connector 22mm x 3/4" Flexible Hose Tap Connector	2 2	FIT9615 FIT9622	
		Compression Flexible Hose Tap Connector - 500mm long (not suitable for central heating) 15mm x 1/2" Flexible Hose Tap Connector 22mm x 3/4" Flexible Hose Tap Connector	2 2	FIT9815 FIT9822	
		Compression Flexible Hose Tap Connector with Service Valve - 300mm long (not suitable for central heating) 15mm x 1/2" Flexible Hose Tap Connector 22mm x 3/4" Flexible Hose Tap Connector	2 2	FIT9715 FIT9722	
		90° Elbow Flexible Hose Connector 90° Elbow Flexible Hose Connector	2	FIT7115F250	

COMPONENT	PRODUCT DESCRIPTION	PACK QUANTITY	CODE NUMBER
	Underfloor Pipe Duct (PVCu) 50mm depth x 150mm width x 3 metre For 10, 15 & 22mm Pipework (requires 12mm thickness Cover Board)	5	FD50
	Underfloor Pipe Duct (PVCu) 70mm depth x 150mm width x 3 metre For 28mm Pipework Requires 12mm Cover Board (Duct only - fittings fabricated on site)	5	FD70
	Push-Fit Union (PVCu) Double Socket for 50mm only	10	FD52
	Push-Fit 90° Angle (PVCu) Double Socket for 50mm only	10	FD53
	Push-Fit 90° Tee (PVCu) Triple Socket for 50mm only	10	FD54
	Push-Fit End Cap (PVCu) Single Socket for 50mm only (insert Solvent Weld pipe clips and base)	10	FD55
	Solvent Weld Pipe Clips (for use with PVCu Pipe Duct) 15mm (ABS) 22mm (ABS) 28mm (ABS) Pipe Clip Base Plate (PVC)	10 10 10 10	FDB15 FDB22 FDB28 FDB93
	Silicone Lubricant, Solvent Cement and Cleaning Fluid Silicone Lubricant 100gm Screw Top Jar Solvent Cement c/w Brush 125ml (BS6209) Solvent Cement c/w Brush 250ml (BS6209) Solvent Cement c/w Brush 500ml (BS6209) Cleaning Fluid 250ml Tin	10 10 10 10 10	SG100 SC125 SC250 SC500 C

POLYSURE SYSTEM

POLYSURE



Polysure is a range of radial press fit fittings, the first in traditional British Standard sizes, for use with Polyplumb or Polyfit pipes in domestic applications. Choosing Polysure combines the benefits of flexible polybutylene pipe systems with emerging press fit fitting technology.

Polysure offers a number of benefits, including:

- Flexible plastic piping eases the installation process and speeds up time to install
- Reduced risk of theft because of low re-sale value of plastics
- Reduced wastage as all pipes used are also compatible with Polyplumb and Polyfit push fit fittings
- Press fit fittings reduce the risk of tampering
- The slim profile brass fittings are easily accommodated into existing buildings
- Polysure provides an enhanced joint to pipes via a visual pipe socket depth indicator and double 'O' ring seal
- Polysure fittings are designed specifically for Polypipe's UK sized pipes
- A location washer for pressing ensures jaws are correctly positioned for pressing onto grey Polyplumb and white Polyfit pipes
- Safe, heat and frame-free with no added cost for jointing consumables

Jointing

There are six stages to completing a joint using Polysure fittings.

Unlike Polyplumb and Polyfit, the Polysure system requires some specialist pressing tools which can be purchased directly from Polypipe or via the manufacturers stockists. Polypipe recommends using REMS pressing equipment who have a reputation for manufacturing durable products that can stand up to today's site conditions. For full details of products, instructions, servicing requirements and warranties please visit www.rems.de

Cutting pipes

Step 1:

Firstly check that the pipe is not scored or scratched in any way and if it is so cut back to a point where there is no damage present.

Pipes should be cut squarely using an approved Polypipe cutter. There is a visual indicator on each fitting which is used to check that the pipe has been inserted into the fitting correctly, therefore, it is not essential that pipes are cut on the K marks. It is however essential that pipes are cut squarely as this may affect chamfering.



Chamfering the pipes

Step 2:

Polysure fittings use press fit technology which seals on the pipe bore so it is necessary to provide an internal lead in on the pipe end so the square edge of the pipe does not damage the 'O' ring seals. On push fit fittings this lead in is provided by the pipe stiffener. Polypipe offer specific pipe chamfering tools for our Polyplumb and Polyfit pipes and these must always be used. The chamfering tools are available in either individual tools or as a block of four dependent on the installers preference however all work in the same way.

The chamfer tool spigot should be inserted into the bore of the pipe until contact is made with the blades then the chamfer tool should be twisted gently to provide a lead in as shown. Any debris should be removed from the pipe end and the chamfer tool. Check that the pipe has been cleanly chamfered around the full diameter of the pipe. If not repeat the chamfering process again.



Insert pipe into fitting

Step 3:

Polysure pipes have a visual indicator to assist in jointing pipes and fittings together. The chamfered Polyplumb or Polyfit pipe should be inserted into the Polysure fitting and pushed in until the pipe can be seen through the hole in the stainless steel pressing sleeve. When this has been achieved the joint is ready for pressing.



Preparing the pressing tools

Step 4:

There are three types of pressing tool recommended for jointing Polysure fittings. The REMS Eco Press is a manual pressing tool which can be used on 10mm, 15mm and 22mm joints only but provides the installer with a light weight, low cost entry pressing tool which can be used in most situations. Alternatively the battery operated tools (mini or standard version) can be used where a high volume of joints needs to be done in a short space of time. The battery operated tools must be used for 28mm fittings.

The 10mm, 15mm and 22mm Polypipe TH pressing jaws have been designed to fit both the manual and standard battery operated pressing tools. The mini pressing jaws are only compatible with the mini pressing gun and can not be used with the manual or standard battery operated guns. All jaws are specifically designed to press Polysure press fit fittings and should only be used for these fittings. Likewise no other pressing jaw should be used for Polysure fittings.

Manual pressing tool

Step 4a:

Secure the jaw in the tool by firstly removing the locking pins from the Eco Press, lining up the holes in the Eco Press with those in the jaw and re-inserting the locking pins.



Battery operated pressing tool

Step 4b:

To insert a Polypipe TH jaw into the battery operated gun, press the release catch on the locking pin on the gun. Slide the jaw into the gun aligning the centre hole in the jaw with the locking pin and push the locking pin back into position until locked.

Once the jaws are locked in the respective machine the pressing tools are now ready to complete the joint process.



Securing the joint

Step 5:

Whether using the manual or battery operated press gun the jaws are located on to the fitting in exactly the same manner.

Do a final check to ensure that the pipe is still inserted fully into the fitting then using the white washer as a location point fix the jaws over the fitting in the un-pressed condition.

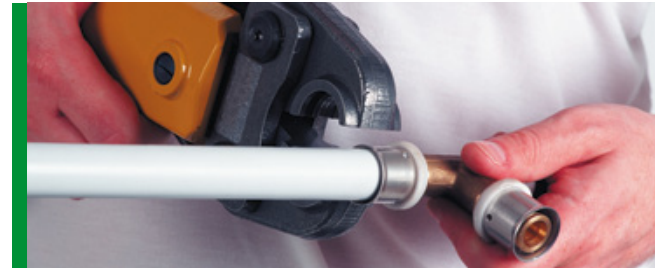

Manual pressing tool

Step 5a:

The levers can now be closed completely ensuring that the two stops on the press tool are touching. Extension pieces are included with the Eco Press if extra leverage is required to completely close the tool.

Only when the tool has been completely closed with the two stops touching is the joint fully secured. The levers can then be opened and the fitting will be released from the jaws.



Battery operated pressing tool

Step 5b:

The trigger can now be pressed on the tool to start the pressing process. Keep the trigger depressed until the jaws have closed completely and the pressing machine clicks to denote the end of the process.

NOTE: once the process is underway it must be completed before the safety catch can be pressed to allow the jaws to be released.









Checking the joint

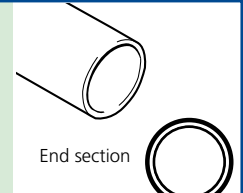

Step 6:

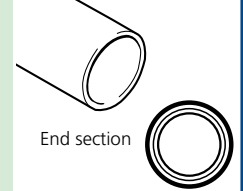

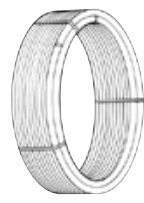

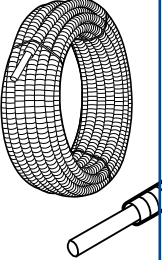

Finally check that the fitting has been pressed successfully by ensuring that the TH pressing profile has been indented consistently around the full circumference of the fitting. Check that the pipe end is still visible through the hole in the sleeve. The white washer should not be damaged or have moved in any way, if so discard the fitting and re-press a replacement fitting. Spare pressing sleeves and washers are available to purchase if required. Once Polysure fittings have been pressed they are not demountable.

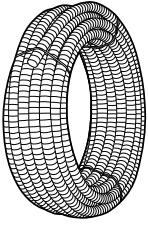
System testing

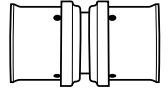
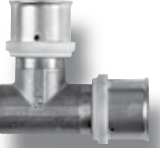
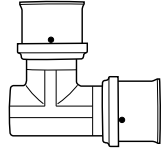
Prior to completing installation it is necessary to fully test the installed system. Please refer to the section on page 46 of this Product Guide for system testing guidance.

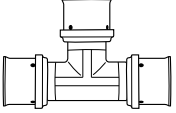

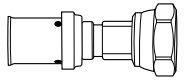

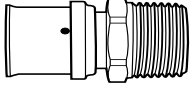
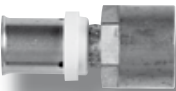
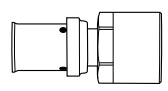
COMPONENT	PRODUCT DESCRIPTION	PACK QUANTITY	CODE NUMBER
	<p>Standard Polybutylene Pipe Cut Length 15mm x 3 metre Cut Length 15mm x 6 metre Cut Length 22mm x 3 metre Cut Length 22mm x 6 metre Cut Length 28mm x 3 metre Cut Length 28mm x 6 metre Cut Length</p>	<p>10 10 10 10 10 10</p>	<p>PB315 PB615 PB322 PB622 PB328 PB628</p> 
 	<p>Barrier Polybutylene Pipe Cut Length 15mm x 3 metre Cut Length (Grey) 15mm x 6 metre Cut Length (Grey) 22mm x 3 metre Cut Length (Grey) 22mm x 6 metre Cut Length (Grey) 28mm x 3 metre Cut Length (Grey) 28mm x 6 metre Cut Length (Grey)</p> <p>15mm x 2 metre Cut Length (White) 15mm x 3 metre Cut Length (White) 15mm x 6 metre Cut Length (White) 22mm x 2 metre Cut Length (White) 22mm x 3 metre Cut Length (White) 22mm x 6 metre Cut Length (White) 28mm x 3 metre Cut Length (White) 28mm x 6 metre Cut Length (White)</p>	<p>10 10 10 10 10 10 10 10 10 10</p>	<p>PB315B PB615B PB322B PB622B PB328B PB628B</p> <p>FIT215B FIT315B FIT615B FIT222B FIT322B FIT622B FIT328B FIT628B</p> 
 	<p>Standard Polybutylene Pipe Coils (featuring "Plumb Straight" coiling technology)</p> <p>10mm x 50 metre Coil (Grey) 10mm x 100 metre Coil (Grey) 15mm x 25 metre Coil (Grey) 15mm x 50 metre Coil (Grey) 15mm x 100 metre Coil (Grey) 22mm x 25 metre Coil (Grey) 22mm x 50 metre Coil (Grey)</p> <p>10mm x 25 metre Coil (White) 10mm x 50 metre Coil (White) 10mm x 100 metre Coil (White) 15mm x 25 metre Coil (White) 15mm x 50 metre Coil (White) 15mm x 100 metre Coil (White) 15mm x 120 metre Coil (White) 15mm x 150 metre Coil (White) 22mm x 25 metre Coil (White) 22mm x 50 metre Coil (White) 28mm x 25 metre Coil (White) 28mm x 50 metre Coil (White)</p>	<p>1 1 1 1 1 1 1 1 1 1 1 1 1 1 1 1 1 1 1 1</p>	<p>PB5010 PB10010 PB2515 PB5015 PB10015 PB2522 PB5022</p> <p>FIT2510B FIT5010B FIT10010B FIT2515B FIT5015B FIT10015B FIT12015B FIT15015B FIT2522B FIT5022B FIT2528B FIT5028B</p> 
	<p>Barrier Polybutylene Pipe Coils (featuring "Plumb Straight" coiling technology)</p> <p>10mm x 50 metre Coil 10mm x 100 metre Coil 15mm x 25 metre Coil 15mm x 50 metre Coil 15mm x 100 metre Coil 15mm x 150 metre Coil 22mm x 25 metre Coil 22mm x 50 metre Coil 28mm x 25 metre Coil 28mm x 50 metre Coil</p>	<p>1 1 1 1 1 1 1 1 1 1 1 1</p>	<p>PB5010B PB10010B PB2515B PB5015B PB10015B PB15015B PB2522B PB5022B PB2528B PB5028B</p> 

COMPONENT	PRODUCT DESCRIPTION	PACK QUANTITY	CODE NUMBER	
	<p>Barrier Pipe-in-Pipe 10mm x 50 metre Coil 15mm x 25 metre Coil 15mm x 50 metre Coil 22mm x 25 metre Coil</p>	<p>1 1 1 1</p>	<p>PIP5010B PIP2515B PIP5015B PIP2522B</p>	
	<p>Conduit Pipe Coils (Polypropylene) 15mm x 25 metre Conduit Pipe Coil (Black) 15mm x 50 metre Conduit Pipe Coil (Black) 22mm x 25 metre Conduit Pipe Coil (Black) 22mm x 50 metre Conduit Pipe Coil (Black) 15mm x 25 metre Conduit Pipe Coil (Red) 15mm x 50 metre Conduit Pipe Coil (Red) 22mm x 25 metre Conduit Pipe Coil (Red) 22mm x 50 metre Conduit Pipe Coil (Red) 15mm x 25 metre Conduit Pipe Coil (Blue) 15mm x 50 metre Conduit Pipe Coil (Blue) 22mm x 25 metre Conduit Pipe Coil (Blue) 22mm x 50 metre Conduit Pipe Coil (Blue)</p>	<p>1 1 1 1 1 1 1 1 1 1 1 1 1</p>	<p>CPC1525 CPC1550 CPC2225 CPC2250 CPC1525R CPC1550R CPC2225R CPC2250R CPC1525BU CPC1550BU CPC2225BU CPC2250BU</p>	

COMPONENT	PRODUCT DESCRIPTION	PACK QUANTITY	CODE NUMBER	
	Straight Couplers 10mm Straight Coupler 15mm Straight Coupler 22mm Straight Coupler 28mm Straight Coupler	10 10 10 10	SUR010 SUR015 SUR022 SUR028	
	Socket x Socket Reducer 15mm x 10mm Socket x Socket Reducer 22mm x 15mm Socket x Socket Reducer 28mm x 15mm Socket x Socket Reducer 28mm x 22mm Socket x Socket Reducer	10 10 10 10	SUR5815 SUR5822 SUR582815 SUR5828	
	90° Elbow 10mm Elbow 15mm Elbow 22mm Elbow 28mm Elbow	10 10 10 10	SUR110 SUR115 SUR122 SUR128	
	Equal Tees 15mm Equal Tee 22mm Equal Tee 28mm Equal Tee	10 10 10	SUR215 SUR222 SUR228	
	Branch Reduced Tees 15mm x 15mm x 10mm Branch Reduced Tee 22mm x 22mm x 15mm Branch Reduced Tee 28mm x 28mm x 15mm Branch Reduced Tee 28mm x 28mm x 22mm Branch Reduced Tee	10 10 10 10	SUR1115 SUR1122 SUR112815 SUR1128	
	End Reduced Tees 22mm x 15mm x 22mm End Reduced Tee 28mm x 22mm x 28mm End Reduced Tee	10 10	SUR1422 SUR1428	
	Branch and End Reduced Tees 22mm x 15mm x 15mm Branch and End Reduced Tee 28mm x 22mm x 22mm Branch and End Reduced Tee	10 10	SUR1522 SUR1528	
	Straight Tap Connector 15mm x 1/2" Straight Tap Connector 15mm x 3/4" Straight Tap Connector 22mm x 3/4" Straight Tap Connector	10 10 10	SUR715 SUR71534 SUR722	
	Bent Tap Connector 15mm x 1/2" Bent Tap Connector	10	SUR1715	
	Male BSP Adaptor 15mm x 1/2" Male BSP Adaptor 22mm x 3/4" Male BSP Adaptor 28mm x 1" Male BSP Adaptor	10 10 10	SUR4315 SUR4322 SUR4328	
	Female BSP Adaptor 15mm x 1/2" Female BSP Adaptor 22mm x 3/4" Female BSP Adaptor 28mm x 1" Female BSP Adaptor	10 10 10	SUR4415 SUR4422 SUR4428	

COMPONENT	PRODUCT DESCRIPTION	PACK QUANTITY	CODE NUMBER	
	Standard Pressing Jaws Polypipe TH Profile Can be used with Manual Pressing Tool (not 28mm) or Standard Battery Operated Pressing Gun 10mm 15mm 22mm 28mm	1 1 1 1	JAW10TH JAW15TH JAW22TH JAW28TH	
	Mini Pressing Jaws Polypipe TH Profile Can only be used with Mini Battery Operated Pressing Gun 10mm 15mm 22mm 28mm	1 1 1 1	MJAW10TH MJAW15TH MJAW22TH MJAW28TH	
	Manual Pressing Tool Manual Pressing Tool Jaws purchased seperately	1	MANPRES	
	Pipe Chamfering Tool Universal Pipe Chamfering Tool	1	UNIPCT	
	Individual Pipe Chamfering Tools 10mm 15mm 22mm 28mm Set of 4 Pipe Chamfering Tools 10, 15, 22 and 28mm	1 1 1 1 1	10PCT 15PCT 22PCT 28PCT SETPCT	
	Standard Battery Operated Pressing Gun Standard Battery Operated Pressing Gun	1	BATPRES	
	Mini Battery Operated Pressing Gun Mini Battery Operated Pressing Gun	1	MBATPRES	
	Pipe Cutters V Bladed Standard Type Cutter 10mm - 22mm	1	PB781	
	Pipe Cutters Ratchet Ratchet Type Cutter Replacement Blade	1 1	PB778 PB779	

SPARES

COMPONENT	PRODUCT DESCRIPTION	PACK QUANTITY	CODE NUMBER	
	'O' Rings 10mm 15mm 22mm 28mm	20 20 20 20	SUR9010 SUR9015 SUR9022 SUR9028	
	Press Sleeve and Washer 10mm 15mm 22mm 28mm	10 10 10 10	SUR9510 SUR9515 SUR9522 SUR9528	

DESIGN APPLICATION & INSTALLATION INFORMATION

The following information is designed to provide basic guidance for installers and specifiers when designing, planning and installing hot and cold water and heating systems using Polypipe products: Polyplumb, Polyfit and Polysure. The information is not exhaustive and guidance may change depending on site conditions and applications. This document should be read in conjunction with all other installation and application instructions available.

Service Conditions

Polyplumb, Polyfit and Polysure are suitable for the following Class S service conditions in a normal domestic operation (subject to the exceptions referred to in note² below):

(Continuously operated re-circulating systems are excluded from these applications)

Application	Nominal system flow temperature Tf °C <small>(see explanatory note below)</small>	Maximum system service temperature Ts °C <small>(see explanatory note below)</small>	System malfunction temperature Tm °C <small>(see explanatory note below)</small>	System maximum working pressure bar <small>(see explanatory note below)</small>
Indirect cold water systems	20	20	—	3½
Direct mains-fed cold water systems	20	20	—	12½
Subsurface heating systems (including Underfloor)	60	83	100	3½
Vented hot water supply systems	65	83	100	3½
Unvented hot water supply systems including instantaneous heaters and/or incorporating storage	65	95	100	6
Vented central heating systems	82	95	100	3½
Sealed central heating systems	82	105	114	3

Note¹:

- nominal system flow temperature Tf is the intended maximum flow temperature of a system for a particular application as recommended in codes of practice and other guidance documents
- maximum system service temperature Ts is the maximum service temperature that can occur intermittently during normal operation
- system malfunction temperature Tm is the maximum temperature likely to be applied to pipes and fittings in the event of control thermostat failure or malfunction

Note²:

- Certain fittings in the Polyplumb and Polyfit ranges are not suitable for all the Class S service conditions. The limitations are indicated against every applicable fitting in the Trade Price List eg "Cold Water Only".

Connections to other materials

Connection to Imperial Copper using Polyplumb

Imperial ¾" copper pipe is of significantly different size to its metric 22mm counterpart and therefore requires a different 'O' ring to that supplied in the 22mm fitting. The 22mm 'O' ring should be replaced with a ¾" 'O' ring (PB9034). Standard 15mm fittings can be connected to Imperial ½" copper pipe, and 28mm fittings can be connected to 1" copper pipe.

Connection to Irish copper pipe

Irish copper pipe to IS238:1980 can be connected to Polyplumb fittings which incorporate the ¾" or 1" adaptor set. Using a standard 22mm or 28mm Polyplumb fitting, remove the nut and socket components and discard. Replace these parts with the relevant adaptor set, ¾" - PB7034 or 1" - PB701. The adaptor sets are distinguishable by the black cap nut.

Connections to chrome plated and stainless steel pipework

Polyplumb and Polyfit fittings should not be connected directly to chrome plated copper pipes or stainless steel pipes. To connect to these pipes we recommend the use of a compression coupler. A pipe stiffener should be used when connecting Polyplumb and Polyfit pipe to a compression fitting.

Connecting Polysure press fit fittings to copper

Polysure press fit fittings have been designed specifically to fit to Polyplumb and Polyfit polybutylene pipes. To connect to copper pipes we advise the use of a Polysure press fit x BSP male or female adaptor, with the corresponding adaptor being used on the copper side from the Polyplumb or Polyfit range. PTFE tape should be used to seal the mating brass components.

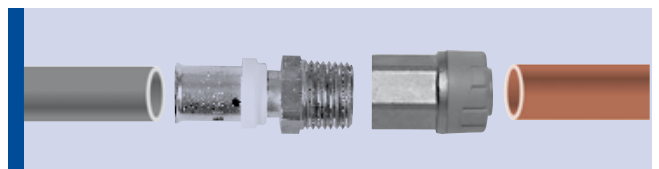

Connections close to capillary fittings

Capillary fittings should preferably be completed prior to the use of Polypipe fittings. Where this is not possible, care should be taken to ensure that flux or solder does not come into contact with plastic pipes or fittings. A damp cloth should be wrapped around the copper pipe close to the nearest plastic pipe or fitting to ensure against damage by conductive heat. Pipework should be flushed to clear flux before active use.

Connections to incoming cold water supply

There are two options for connecting incoming MDPE mains water service pipe to Polyplumb and Polyfit pipe systems. Firstly the push fit x compression adaptors provide a one piece transition fitting covering connections from 20mm, 25mm and 32mm MDPE service pipes to 15mm, 22mm and 28mm polybutylene pipes and most sizes are available in both Polyplumb and Polyfit versions. Secondly, as there is a requirement for a stopcock on the incoming main there is also a combined stopcock and adaptor which reduces the number of fittings required in a position where there is often limited space e.g. under a kitchen sink. These products allow connections from 20mm or 25mm MDPE pipe via a compression end to 15mm or 22mm polybutylene using a push fit connection.



Pushfit x compression adaptor



Combined stopcock and pushfit x compression adaptor

Gas, oil, and compressed air

Pipes and fittings must not be used for gas and oil supply pipework or compressed air pipework.

In all the above instances metal pipework should be installed.

Continuously operated re-circulating systems (Secondary Hot Water Circulation / Ring main installations)

A continuously operated re-circulating system is a water-replenished circulating system which is maintained at a constant high temperature to provide a constant source of hot water. Continuously operated re-circulating systems are used to distribute constant hot water to wards or rooms that may be distant from the heat source or hot water storage vessel. Locations where continuously operated re-circulating systems are used include, but are not limited to, residential care homes, hospitals and hotels. Continuously operated re-circulating systems are very different from conventional hot water supply and central heating systems found in domestic properties, for which our products have been tested to, under either BS 7291 Class S or WRAS approval standards, and for this reason Polyplumb, Polyfit or Polysure should not be used on any continuously operated re-circulating systems.

Re-cycled rainwater systems

Polypipe products can be used in systems conveying re-cycled or harvested rainwater within domestic properties. All pipe work used in this type of system should be clearly identifiable and this should be carried out in accordance with regulations. If self adhesive labels are to be used, these should not be applied directly to the pipe.

Chlorine and other additives

The polybutylene material used in Polyplumb, Polyfit and Polysure pipes and fittings is WRAS approved. It is resistant to the buildup of scale. Normal levels of chlorine in UK domestic water supplies will not have an adverse effect on Polyplumb, Polyfit and Polysure.

However Polyplumb, Polyfit and Polysure are not suitable for systems in which any further additives are ever added, periodically added, or regularly dosed in to or additional to the normal mains water supply, for example chlorine for swimming pools or those used for bacteria control or legionella prevention. Systems must not be flushed through with anything other than water from the normal mains water supply or a cleaning product at the correct concentration that is specifically recommended for plastic piping systems.

The use of corrosion inhibitor in central heating systems is acceptable provided that the inhibitor is specifically designed for plastic piping systems and guidance on their suitability should be sought from the inhibitor manufacturer prior to adding to the system.

Light

Polyplumb & Polyfit pipe and fittings should be protected from UV light. Standard decorating paints form adequate protection. Pipe insulation forms adequate protection for external use. Polypipe products are delivered in light protective packaging.

Compatibility with other substances

For details of compatibility with building and cleaning substances, and treatments (eg filler foam and wood worm treatments) please consult the relevant manufacturers to confirm suitability with Polybutylene. Polyplumb, Polyfit and Polysure pipes and fittings can be painted using emulsion or undercoat and gloss. Cellulose based paints, strippers or thinners must not be used.

Vermin

There is no evidence to suggest that Polyplumb, Polyfit or Polysure attract vermin. Where vermin are present they can cause damage to other services, building fabric and pipes and fittings, and therefore a qualified pest controller should be employed to remove vermin from the affected area.

Connections to other equipment

Boilers and appliances:

All boilers and appliances must have safety devices such as thermostatic controls, cut-outs and pump over-run protection to make sure that they cannot operate above the Class S working temperature and pressure limits set out in the table of Class S service conditions on page 37. Exposure to conditions in excess of those specified could result in failure of the pipes or fittings with the potential for serious injury.

Gas Boilers:

Pipe should only be connected to gas boilers where the pipe connection is outside the boiler casing and where the boiler incorporates a high limit thermostat and pump over-run facility. The pipe connections should be 350mm from the heat source. In all other situations, a section of metal pipe should be at least 1m in length. In addition for back boilers metal pipe work should be used within the fire opening extending out of the chimney brickwork.

Combination Boilers:

Where system connections are made to an incoming water supply pipe from a water meter or any other device which contains a check valve a suitable expansion vessel must be fitted to prevent the expansion of heated water back down the supply pipe. This is especially important where a water meter is fitted retrospectively.

Solid Fuel Boilers & Cooking Ranges:

Pipes and fittings must not be used for primary or gravity circuits from solid fuel boilers, cooking ranges or other uncontrolled heat sources.

Solar Panels / Systems

Pipes and fittings must not be used for connection of solar panels or any part of solar distribution that operates above the Class S working temperature and pressure limits set out in the table of Class S service conditions on page 37.

Electric Water Heaters:

Polypipe products can be connected directly to electric water heaters, however, if the unit has no maximum temperature control we would recommend that you follow the same guidelines as above for boilers, care must be taken to follow the manufacturers (of the water heater) guide lines for installation.

Oil Fired Boilers

Open Vented Central Heating Systems:

The use of plastic pipe and fittings is acceptable when used in oil fired installations where the boiler is connected to an open vented system, however the first metre of primary pipework from the boiler connections must be installed using metal pipe. The boiler must be suitable for this type of application and all relevant safety features as supplied and fitted to the boiler must be checked for correct operation. The system must also be commissioned in accordance with the boiler manufacturers instructions.

Plastic pipe and fittings can also be used in the hot and cold water and underfloor central heating systems with the exception of continuously operated re-circulating systems where plastic pipe and fittings should not be used.

For further information regarding the suitable applications for our plastic pipe and fittings please refer to the Class S Service Conditions in this publication.

Sealed Central Heating Systems:

Where a sealed system oil fired boiler is to be used all primary boiler pipework to and from the hot water cylinder (if fitted) and any radiator or towel rail circuits must be installed using metal pipe and fittings.

Plastic pipes can be used on underfloor central heating systems where the plastic pipes are fitted after the UFCH control unit and manifold arrangement which must contain a correctly operating thermostatic mixing valve.

Plastic pipe and fittings can also be used in the hot and cold water system with the exception of continuously operated re-circulating systems where plastic pipe and fittings should not be used.

All relevant safety features as supplied and fitted to the boiler such as the boiler temperature control thermostat, high limit thermostat, pump overrun facility and the pressure and temperature relief valve must be checked for correct operation at both installation stage and at any subsequent boiler service intervals. The system must also be commissioned in accordance with the boiler manufacturers instructions.

For further information regarding the suitable applications for our plastic pipe and fittings please refer to the Class S Service Conditions table in this publication.

Cylinders:

All pipework in the cylinder cupboard should be from cut lengths rather than coils and should be clipped to a pipe board rather than the wall using screw clips

at 300mm centres. Pipe clip spacers should be used to achieve crossovers where necessary.

Connections to sanitary appliances:

The connection to sanitary appliances such as baths, basins, sinks and WC's is easy with the Polypipe product ranges. With a wide range of fitting types to choose from every eventuality is covered. Swivel tap connectors with brass connecting nuts are available in Polyplumb, Polyfit and Polysure versions. There are hand tighten tap connectors available in Polyplumb and Polyfit for those difficult to access places. A number of specialist products are also available which incorporate valves into appliance connectors. Both straight and bent valved connectors are available as well as versions in both plastic and chrome plated brass.

Polypipe supply both a conical seal (attached to the connector) and a flat seal (supplied loose with each individually packed tap connector) with each swivel style brass nut tap connector. As we do not know what type of tap is being installed it is the installers responsibility to ensure that the seal supplied is compatible with the tap to ensure a water tight seal is made.

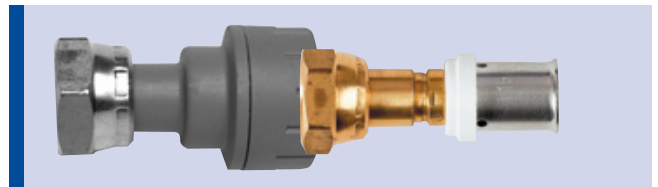

Polyplumb and Polysure swivel tap connector with brass nut



Polyfit hand tighten tap connector

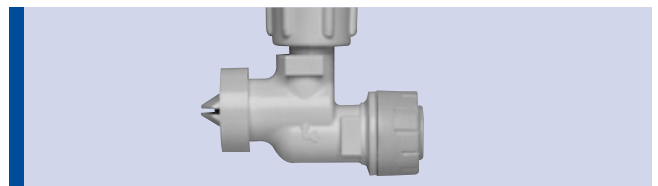

Polyplumb bent valved tap connector



Polyfit straight valved tap connector

Finally the Polyfit range contains one of the widest ranges of flexible connectors on the market with products of varying lengths and connection type. Connections to $\frac{1}{2}$ " and $\frac{3}{4}$ " taps are covered as well as products which include built in service valves. There are also specialist products which are available for connection to monobloc mixer taps and a space saving elbow pattern connector.

Polyplumb terminal fitting:

Where wall mounted taps are being utilised the use of a conduit terminal box is recommended. The fitting consists of a 15mm x $\frac{1}{2}$ " female elbow which is housed in a plastic terminal box allowing the hot and cold water supply pipes to be hidden in a wall cavity. The terminal elbow can also be mounted onto a backing plate which assists installation and centring the taps. Once installed, taps can be screwed into the female threaded elbow and the wall finish applied to give a neat cleanly designed environment.

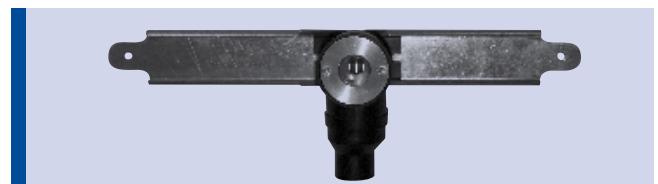

Connecting to radiators:

As with connections to sanitary appliances there are a number of options for connecting pipes to radiators. Available within the ranges are spigot elbows for 10mm and 15mm connections as well as a 10mm x 15mm version which allows 10mm pipes to be connected

directly into a 15mm radiator valve without the need for additional reducers. The Radiator Connector Bend "RCB" provides installers with an attractive method of connecting 10mm or 15mm Polypipe pipe from walls or floors to radiators. The rigid white 100mm x 150mm bend can be cut to length and connects directly to Polypipe fittings and radiator valves and requires pipe stiffeners in each end.

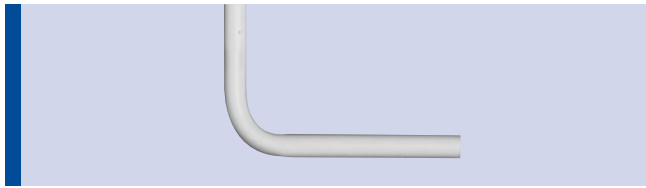

Use of aluminium tape

To comply with the UK guidelines regarding detection of pipes in wall cavities Polypipe recommends the use of aluminium tape. This tape should be applied directly to the wall sub-structure and pipes should be clipped on top of the tape. The tape must not be applied directly to the pipes.

Radiator terminal plate

The new Polypipe Radiator Terminal Plate is a multi functional product for use in Polyplumb and Polyfit piping systems.

- It provides an air tight seal around pipework entering rooms from wall cavities to feed radiators
- Gives a neat and secure entry point for pipes serving radiators.
- Ensures pipes are not damaged by rough edges of wall boards or plaster boards
- Can be fitted with or without a single gang electrical back box (supplied by others)

Product features

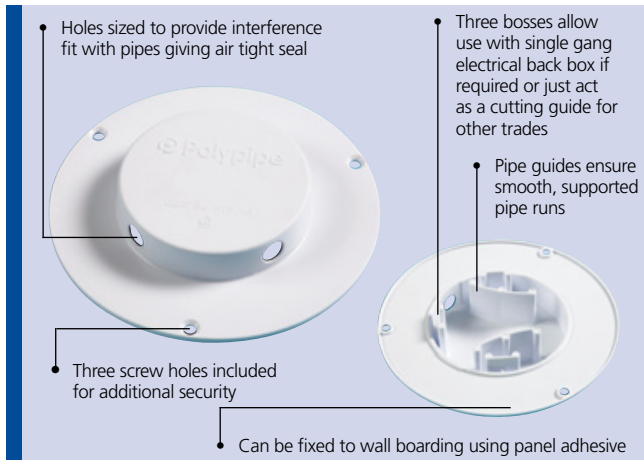

Installation instructions

Installing flow and return pipework

Step 1 :

Install 10mm flow and return pipework down sub-wall with continuous loop long enough for radiator feeds through wall. Pressure testing of the heating system must be carried out at this stage.

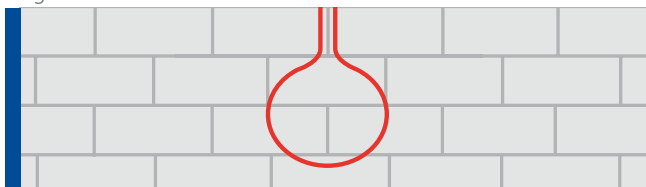

Preparing the wall boarding

Step 2:

Cut a hole the size of a standard electrical back box in the wall boarding. For guidance use the three bosses on the reverse side of the Polypipe Radiator Terminal Plate.

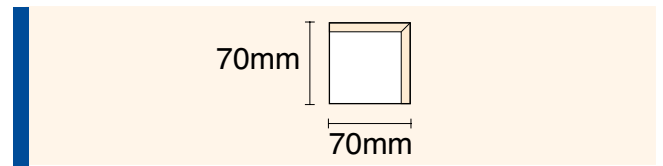

Cutting the pipes

Step 3:

Cut pipes at appropriate point to allow for wall board to be installed ensuring enough pipe is left to reach valves at each end of the radiator.

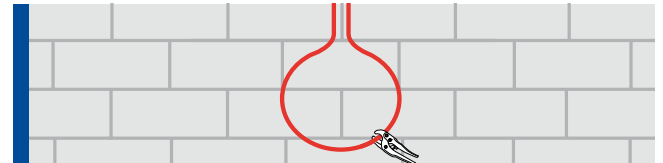

Pipe threading

Step 4:

Thread pipes through hole cut in wall board taking care not to scratch or damage pipes.

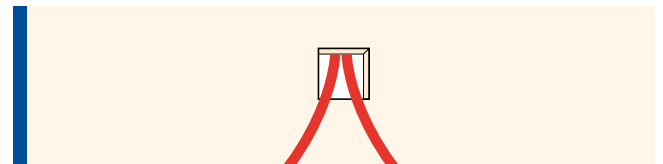

Fit Radiator Terminal Plate on to pipes

Step 5:

Pass the pipes through the radiator terminal plate from back to front using the pipe guides to aid routing. They should be a tight interference fit through the holes which provides the seal. Cutting the ends of the pipes at an angle may help to thread pipes through the hole but remember to cut pipes square again before connecting into a fitting.

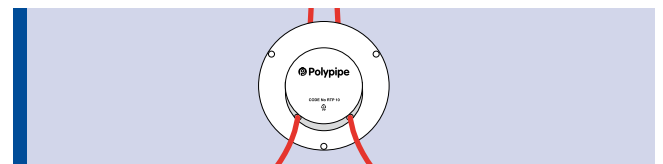

Securing the Radiator Terminal Plate

Step 6:

Use panel adhesive to seal the Polypipe Radiator Terminal Plate to the wall board and if necessary use tape or three countersunk screws to hold the plate in position whilst the adhesive sets.

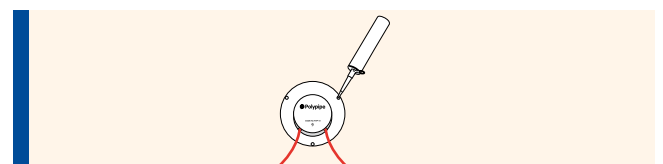

Fitting the Radiator

Step 7:

Fit radiator and valves and connect the pipes as per normal installation instructions.

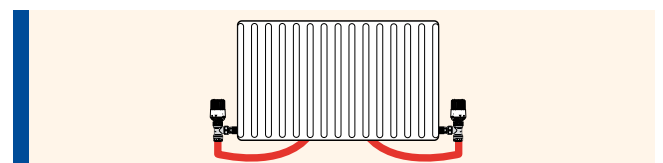

Pipework installation

Minimum bending radius

The minimum bending radius of unsupported Polybutylene pipe is 12 times the pipe diameter. Bends can either be supported at each end of the bends using pipe clips where possible. Alternatively, bends can be supported by a bend former (PB6315 or PB6322) where only one screw hole is required, and the minimum bend radius is 8 times the diameter.

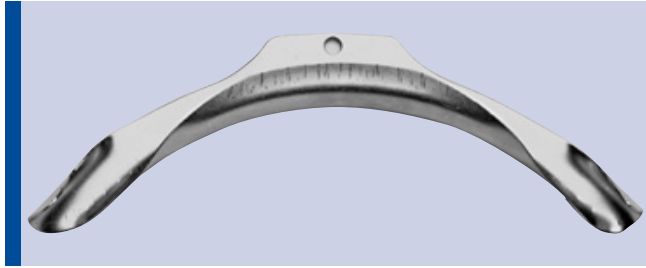

Bend former

Minimum bending radius

Pipe diameter (mm)	10	15	22	28
Unsupported (mm)	120	180	264	336
Supported (mm)	80	120	176	224

Pipe cabling

The main benefit of using Polypipe polybutylene pipes is that the pipe flexibility allows pipe to be cabled through the fabric of the building offering the following advantages.

New build applications

- Allows 1st floors to be laid before plumbing is installed. Plumbing can be installed through holes drilled in joists.
- Site safety is enhanced as pipework can therefore be installed from below.
- Post installation repair work is reduced, as expansion noise due to trapped pipes does not occur, and leaks due to nailed pipes are avoided.

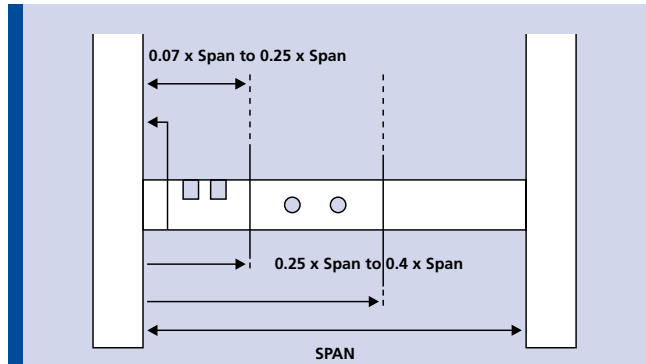

Position of notches and holes

Alterations to existing systems

- Less disruption to property as floors and carpets may not have to be removed in some rooms.
- Kinder to building structure, as existing joists may not allow further notching.
- Pipes can be cabled around existing obstructions.
- Safety is enhanced as no naked flames are required.

Polybutylene pipe provides installers with the flexibility of installing pipes through both holes and notches in joists, choosing the most appropriate method. Building Regulations provide instructions on the drilling and notching of floor joists however an example is shown below.

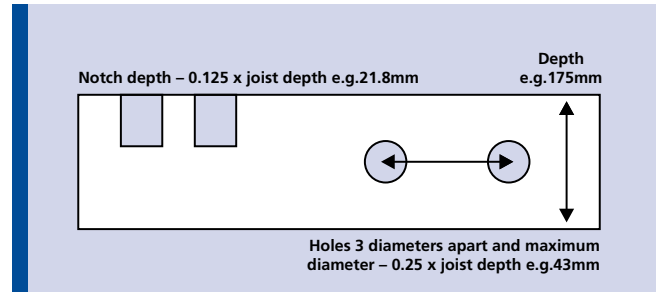

Size of notches and holes

Pipe supports

All pipes should be correctly supported using either nail-in, snap-fit or bulldog clips. Where required spacer pieces are available for the snap-fit clips. All pumps and valves must be correctly supported to prevent unnecessary strain on the pipework.

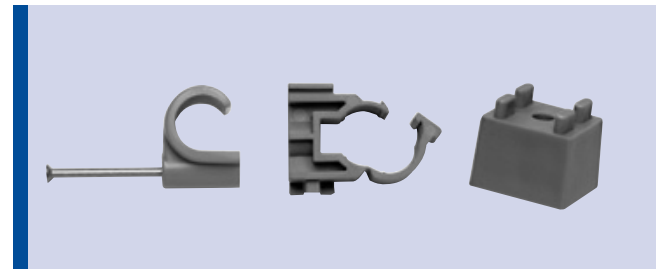

Nail-in clip and snap-fit with spacer

Minimum support centres

	Horizontal pipes	Vertical pipes
10mm & 15mm	0.3m	0.5m
22mm	0.5m	0.8m
28mm	0.8m	1.0m

System design

Although flexible systems can be used in exactly the same way as rigid systems, the flexibility of the pipe allows more design options which may benefit the installer, the building, or during future maintenance.

The general theory of designing water systems in Polypipe products is to use the flexibility of the pipe to its best advantage and therefore using fewer fittings. This not only ensures the most cost-effective use, but also allows fewer joints and hence improved flow around changes of direction. The flexibility of the pipe allows jointing to be made in fewer locations and joint locations can more easily be made accessible.

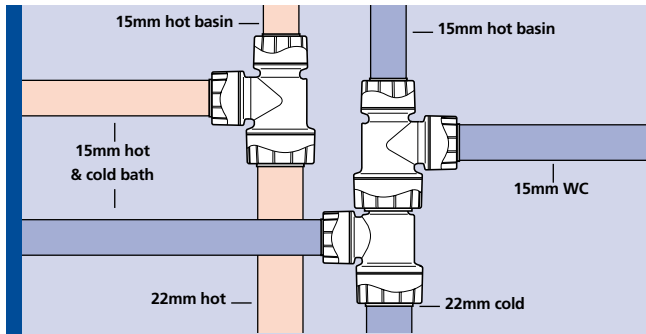

Example water system design

Use of 10mm pipe for heating applications

Use of 10mm pipe for heating applications. As 10mm pipe is so flexible and can easily be positioned behind dry lining, its use offers many installation advantages. As it is the smallest of the pipe diameters offered in the Polypipe ranges, restrictions on the use of 10mm pipe should be considered. The table below gives a guide on the restrictions of using 10mm pipes with Polyfit and Polyplumb fittings. When using 10mm Polysure fittings we recommend that the length of 10mm branch pipe runs are as short as possible and preferably no longer than 3 metres (6 metres for flow and return) and radiator outputs are restricted to a maximum of 1kW.

EXAMPLE: 10m of pipe prior to 10mm connection (5m flow, 5m return) used with 1.25kW Radiator. Maximum length of 10mm = 13m (6.5m flow, 6.5m return).

Max length of pipe prior to 10mm connection e.g. 10m = 5m flow and 5m return	Maximum length of 10mm pipe total e.g. 13m = 6.5m flow and 6.5m return		
	1 kW Rad	1.25 kW Rad	1.5 kW Rad
5	24	15	11
6	23	15	11
7	22	15	10
8	22	14	10
9	21	14	10
10	20	13	10
11	20	13	9
12	19	13	9
13	19	12	9
14	18	12	8
15	17	11	8
16	17	11	8
17	16	10	8
18	15	10	7
19	15	10	7
20	14	9	7

Polyplumb manifold system

For use in most domestic hot and cold water supply and radiator heating projects, Polyplumb manifold systems provides a central connection point for water distribution.

Manifold plumbing which is ideally suited for use with Polyplumb “pipe-in-pipe” technology (where screed embedded pipework is used with minimal joints) is employed in a similar way to simple electrical circuits in that all services are supplied from an easily accessible central distribution unit that can be either wall mounted, placed in an unobtrusive void or housed within an inspection box and subsequent supply pipework cabled through wall, floor or ceiling voids. Although manifolds are available in various port configurations they can be close coupled together to create manifolds with any number of outlets.

Application of manifolds in central heating

Polypipe manifolds are dimensionally compact and can be used in joisted floors or ceiling voids for in-line distribution. They are normally used unvalved, as each radiator has valves on for isolation purposes.

There are both single and double sided versions with 10mm ports and in-line side versions with 15mm ports. Being lightweight they can be simply used inline without bracketed support as long as the pipework is adequately supported.

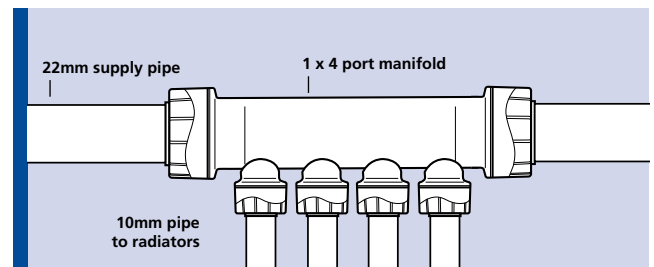

Polyplumb 4-port manifold for radiator supply

When heating supply is to be used with a screeded floor, (where no joints are allowed below the floor surface) a 22mm pipe-in-pipe main supply is used. This supply would exit the floor, pass through the manifold system above the floor surface, and re-enter the floor to the next manifold supply point elsewhere in the building.

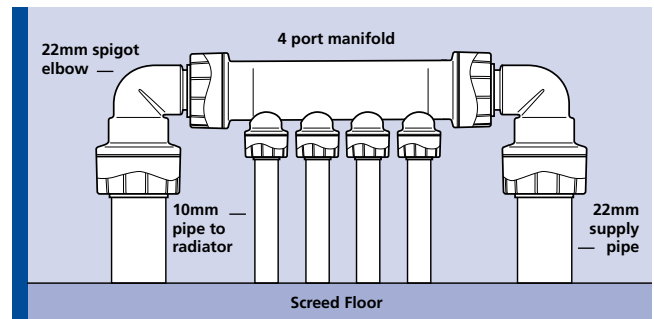

Manifold used above a screeded floor

The supply to each radiator would then be taken off the manifold, these single sided unvalved manifolds are available in both brass with 15mm ports or plastic with 10mm or 15mm ports (10mm pipe for small radiators or short runs and 15mm for longer runs or larger radiators).

Application of manifolds for hot and cold water supply

There are two ways that the manifold system can be employed in hot and cold water supply, the benefits of which are that all pipework is concealed but fittings are above floor level and can be hidden away in cupboards and voids. Services can be isolated where needed using the valved manifolds.

Localised supply is where the manifold is placed unobtrusively within a void or cupboard or under the bath in the area supplied, i.e. bathroom, en-suite or kitchen area. The 22mm supply pipe is fed through the house to the manifold and then secondary supply pipes are taken out of the ports to feed each appliance, e.g. basin, bath or shower.

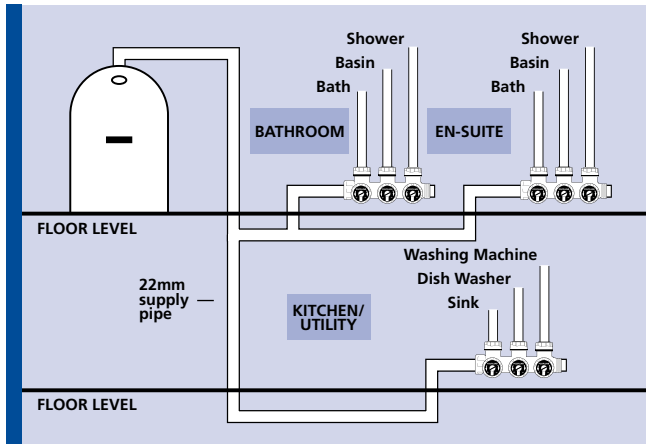

Localised supply design layout

Centralised manifold supply is where the manifold distributes water to each appliance directly from a central cylinder cupboard, where a series of valved manifolds are dedicated to each area, i.e. bathroom, en-suite, kitchen or utility room.

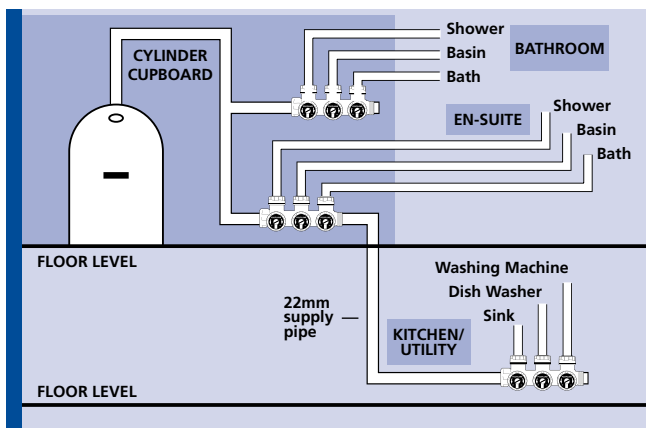

Centralised supply design layout

Using manifolds to create extra ports

One clever design feature of the Polyplumb Manifold Range is that both polybutylene and brass manifolds can be joined together to create extra ports where required.

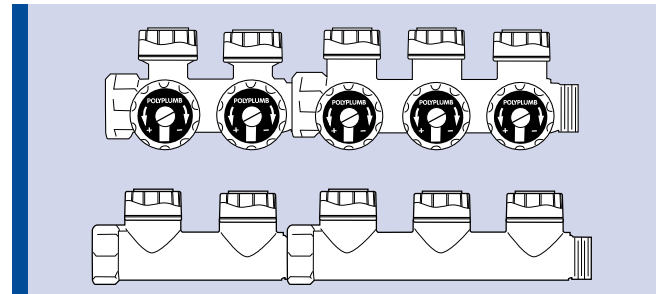

Joining together of manifolds increases number of ports

Manifold options

There are three distinct variations of manifolds that can be employed. Both brass and plastic non-valved (with separate push-fit ball valves if required) or brass integrally valved manifolds can be used. Manifold brackets are also available for brass products.

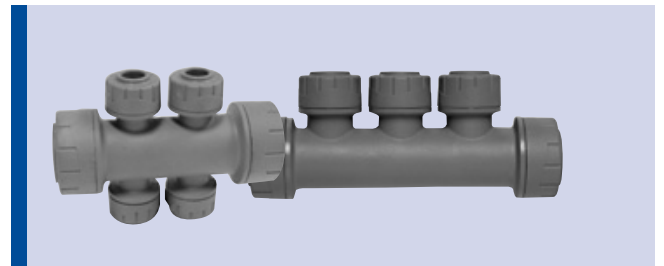

Polybutylene double sided manifold - 4 port and Polybutylene single sided manifold - 3 port

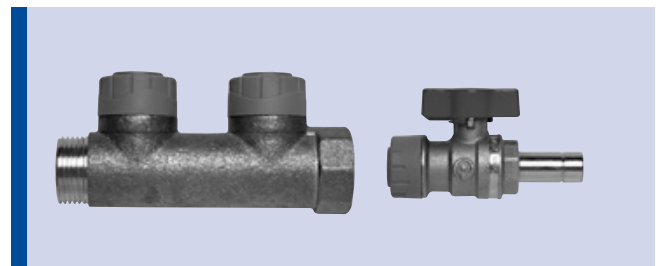

Brass single sided manifold unvalved - 2 port and Ball valve brass

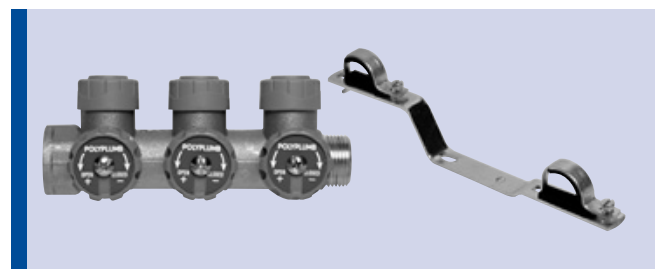

Brass single sided manifold valved - 3 port and manifold bracket

Conduit Pipe and Pipe-in-Pipe

The conduit pipe coils (CPC15XX and CPC22XX) provide a conduit pipe which allows 15mm and 22mm pipes to be laid in a floor screed whilst also providing protection.

The installation and application of the system is described in the following section. The conduit pipe used in conjunction with the conduit boxes (JIB1 and JIB3) which house fittings, provides a cost effective and practical pipework solution.

Polyplumb Pipe-in-Pipe consists of a polybutylene barrier pipe encased within a black conduit pipe.

The conduit provides protection for the polybutylene pipe in the installation process as well as allowing easy withdrawal for future alteration or maintenance.

Installing conduit systems

Positioning the conduit box

Step 1:

Loosely position conduit boxes where required.

Assembling fittings

Step 2:

Assemble fittings in boxes

HANDY TIP: Where boxes abut a wall, i.e. elbows beneath radiators or sanitary appliances, boxes can be cut in two with the open end abutting the wall, this reduces the number of boxes required.



Positioning drill holes

Step 3:

Drill conduit box using fitting assembly to determine hole position.

Fixing the conduit box

Step 4:

Fix conduit box to floor.

HANDY TIP: Use round drilled out sections of conduit box as washers.

Preparing the pipe

Step 5:

Make joint at one end of pipe to be installed and cut pipe to length required.

Cutting conduit pipe

Step 6:

Cut conduit to length required before threading conduit over pipe and through hole in box to 2 or 3 corrugations.

Securely fitting conduit pipe

Step 7:

Push away pipe from end yet to be connected to allow grip onto the pipe and push the pipe into the fitting before allowing conduit to cover pipe. Push conduit through hole in box to 2 or 3 corrugations.

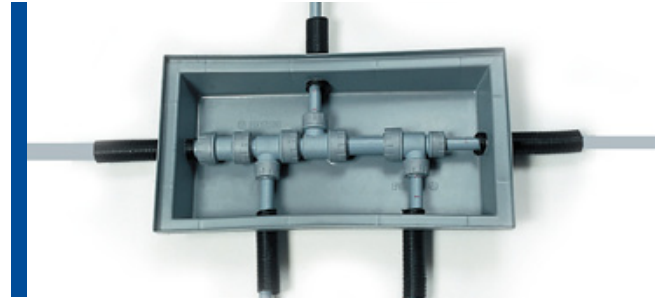

Joints in screeded floors due to accidental damage

Where it is necessary to have joints in screeded floors, these joints must be accessible. For example, where accidental damage to a pipe has occurred, the damaged section of pipe must be removed and replaced. The section containing the joints must be installed within a Junction Inspection Box. Junction Inspection Boxes are manufactured to suit two screed depths; 65mm (Product Code JIB3) - black in colour and 75mm (Product Code JIB1) - grey in colour. Both accept the 12mm plywood lid (Product Code JIB2) to provide future access should it be required.

Pipe and Fitting Blanking

Pipes and fittings may need to be temporarily or permanently blanked for testing, avoidance of construction debris or for future connections.

There are a number of options for blanking pipes in the Polyplumb and Polyfit ranges. For example for permanent capping off of pipes we would recommend the use of a Polyplumb socket blank (product code PB19XX) or where blanking off is only a temporary measure then either a Polyplumb demountable cap end (PB69XX) or Polyfit socket blank end (FIT19XX) is ideal.

Fittings can be blanked off using either a Polyplumb blank end (PB9XX) for permanence or a Polyfit version (FIT9XX) which features handy finger slots for gripping when demounting when used in temporary situations.

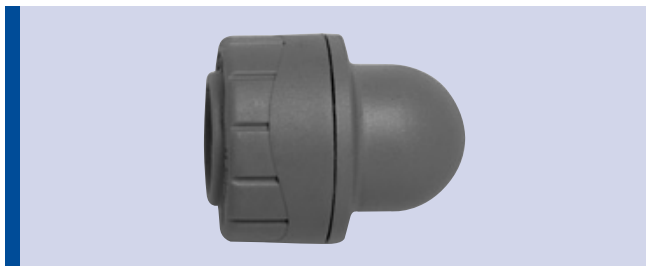

Polyplumb Socket Blank End

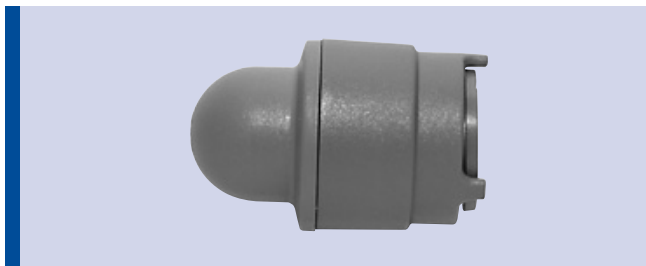

Polyplumb Demountable Socket Blank End

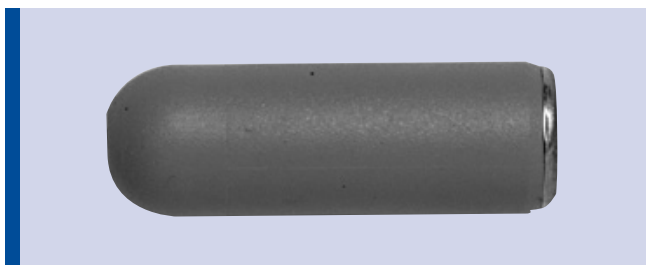

Polyplumb Spigot Blank End



Polyfit Socket Blank End

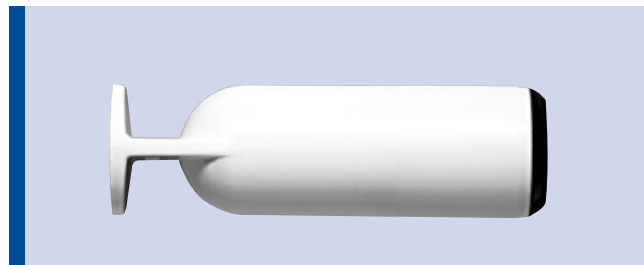

Polyfit Spigot Blank End

Painting

Pipes and fittings can be painted using emulsion or undercoat and gloss. Cellulose based paints, strippers or thinners must not be used.

Electrical safety

Where Polypipe pipes break the continuity of existing metal pipe, which may be used for earthing, or bonding this continuity must be re-instated by affixing permanent earth clips and a section of earth cable between the copper ends on either side of the plastic sections.

Equipotential bonding

Both the IEE and the Chartered Institute of Plumbing and Heating Engineers now give guidance on the Earth Bonding requirements of Plastic Pipe systems. As plastic pipes do not conduct electricity, installations generally require less equipotential bonding than metal systems although if in doubt exact guidance should be sought.

Handling and storage of products

The packaging of both pipes and fittings is designed to protect from ultraviolet light and environmental contamination. Pipes and fittings should therefore be retained in their packaging as long as possible, and should be stored in a cool dry area.

When on site, fittings should be stored to prevent dust and debris from entering the fitting and sticking to the pre-lubricated 'O' ring. Care should be taken to avoid scratching the pipe surface during the handling, storage and installation processes

SYSTEM TESTING

Essential pressure testing of systems.

1st fix Installations

Step 1:

Pipe and fittings only should be tested. The system should be completely filled using water at not more than 20°C at a test pressure of 18 bar which should be applied for not less than 15 minutes and no longer than 1 hour. Joint security can be checked visually and by tugging at joints.

2nd fix Installations

Step 2:

Complete installations including appliances should be tested with water to the maximum test pressure allowed by manufacturers of the appliances and fittings.

Please note, due to health and safety reasons pipework installations must not be air tested.

Pressure testing in sub zero temperatures

Special precautions are necessary if the pressure testing is to take place in sub-zero temperatures.

This applies particularly in under floor central heating systems using the screeded floor system where most of the pipe is encased in concrete. Due to the contact between pipe and floor panel on screeded installations, where the screed does not completely surround the pipe, there may be points where strain is created on the pipe in freezing conditions which is not normally present.

Therefore it is advisable to drain the under floor central heating system once testing and screeding has been completed.

Precautions should also be taken where installations contain large quantities of fittings which due to the rigidity of their construction may put undue pressure on the pipe.

EXTENSIVE SUPPORT SERVICES

Standards

Polypipe meets, and constantly strives to exceed, the changing laws and regulations governing our operations and products.

We have invested in extensive testing and development facilities to ensure the products we supply are of the highest quality. Our plumbing systems conform to a number of 3rd party accredited standards which are listed below.



- British Standard Class S rated to BS7291 Part 1 and Kitemark Licence Number 38148 to BS7291 Part 1 & 2.



- Polyplumb polybutylene barrier pipe, fittings and accessories are covered by BBA Certificate No 00/3699.



- Listed in the WRAS Water Fittings and Materials Directory.



FM00318

- Standards Manufacturing Quality Assurance - in accordance with BS EN ISO 9002 (BSI registered firm Certificate FM00318).

We have invested significantly in our quality control procedures, have our own fully-equipped modern laboratory for development and analysis, and also have our own tooling and extrusion processes.

- Installation Standard must follow the requirements of BS5955 - PART 8 2001 Plastic Pipework (Thermoplastic Materials).

Guarantee

Polypipe guarantees for 25 years against defects in materials or manufacture of the Polyplumb and Polyfit hot and cold water supply and heating systems from the date purchased. This guarantee only applies if the products are installed in accordance with the manufacturer's recommendations and are used in a normal domestic operation.

CENTRE OF EXCELLENCE

Polypipe has created a new, purpose-built training and development facility - the Centre of Excellence - at its Aylesford site in the UK, demonstrating its commitment to invest in people and training. Spacious and well appointed, the Centre of Excellence provides exhibition, training and demonstration facilities for consultants, clients, contractors, installers and distributors. Major investment in the Centre allows us to provide instruction in our entire product range.



Plumbing & Heating Systems



Polypipe Gulf FZE

Dubai Airport Free Zone (DAFZA)
P.O. Box 54897
Building 4E-A
Office 213
Dubai
United Arab Emirates
Tel: +971 (0)4 609 1371
Fax: +971 (0)4 609 1372

Polypipe Terrain

New Hythe Business Park
College Road
Aylesford
Kent
ME20 7PJ
United Kingdom
Tel: +44 (0)1622 795200
Fax: +44 (0)1622 716796

international@polypipe.com

www.polypipegulf.com